

Desenho Mecânico II
(TMEC012)

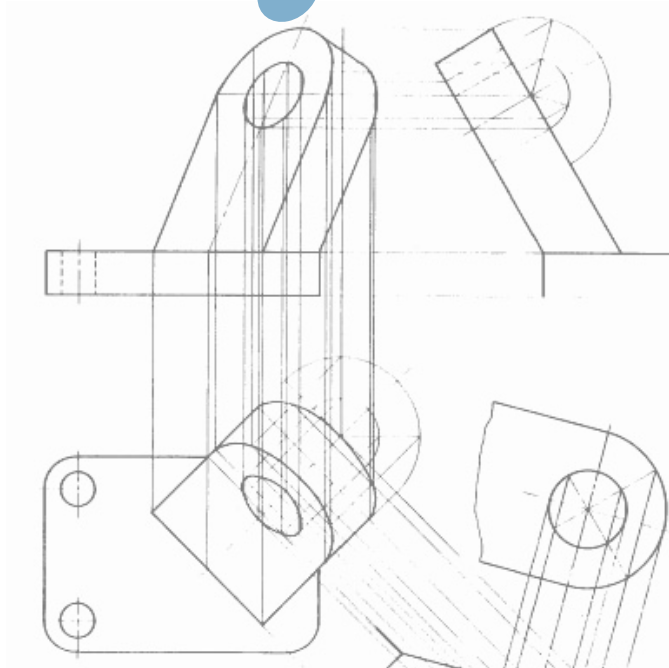

Exercícios

Praticando Modelagem

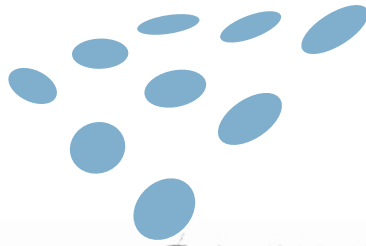
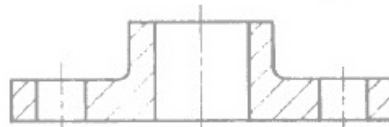
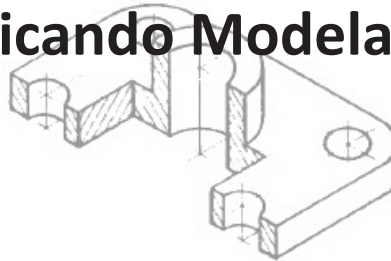

corte AB

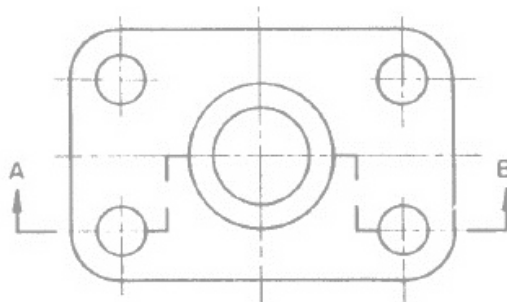

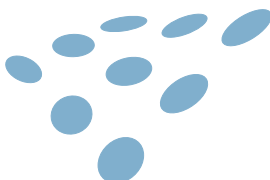

Desenhos 1 - Base de cursor

MEDIDAS EM MILÍMETRO

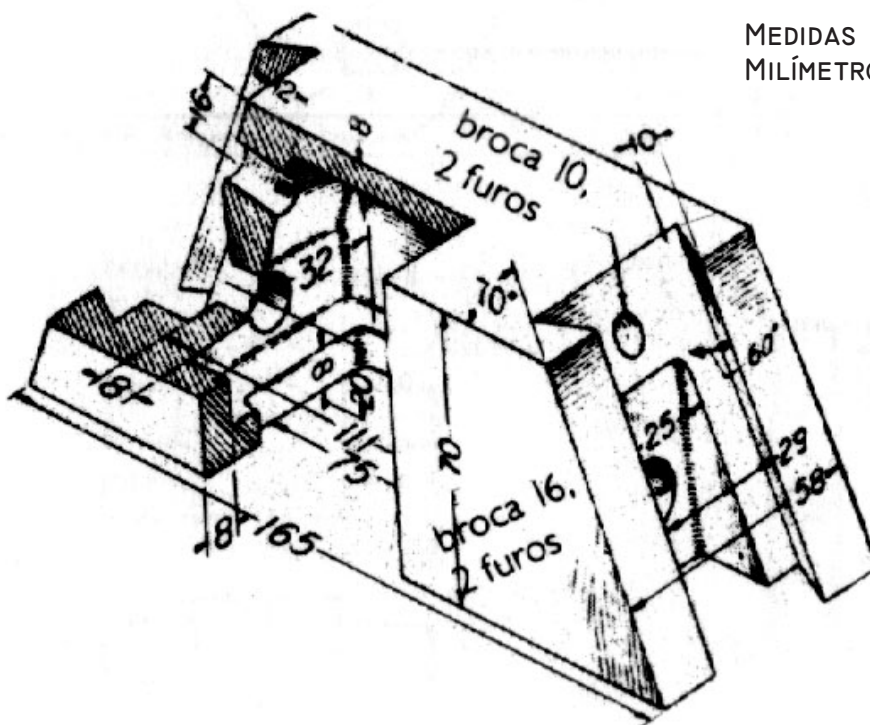

Desenhos 2 - Articulação da base de tração

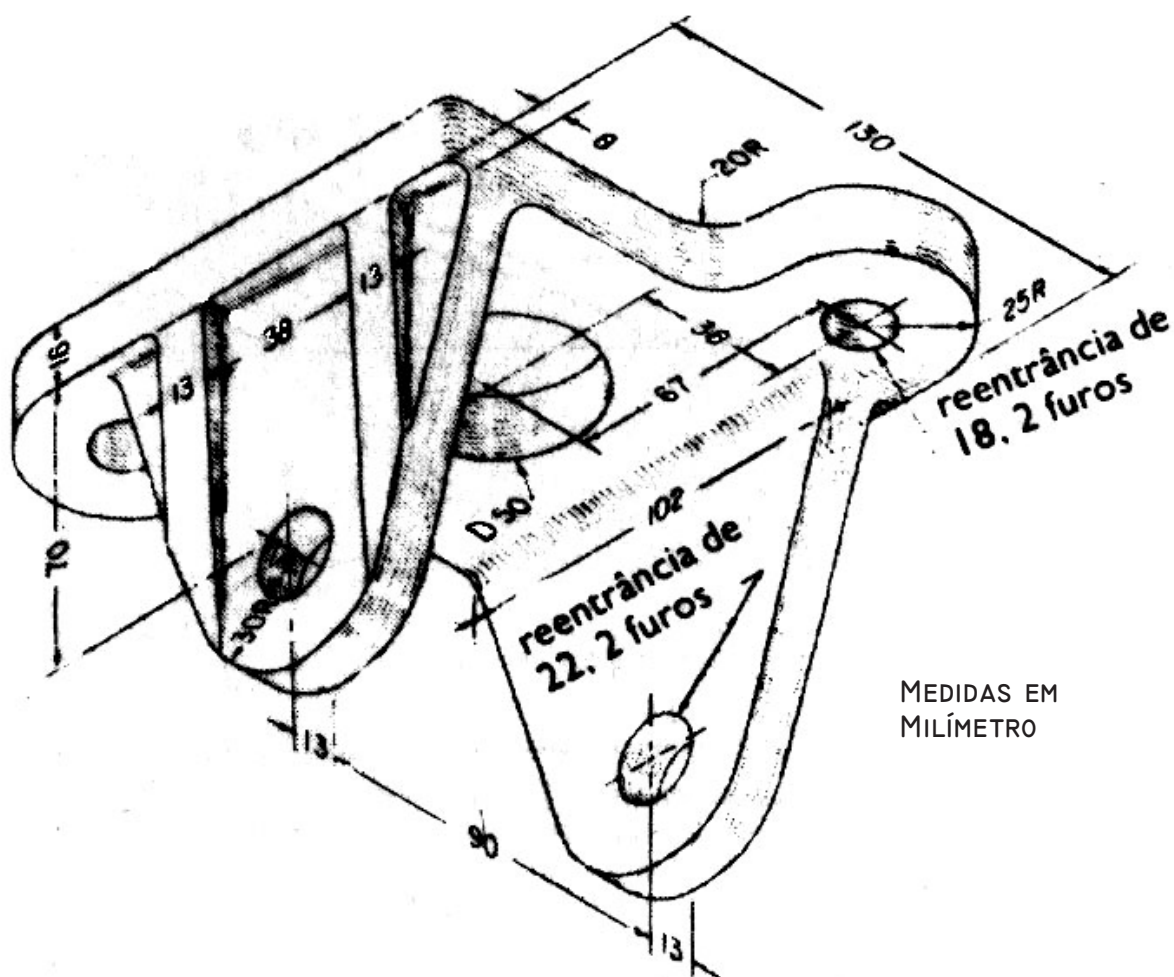

MEDIDAS EM MILÍMETRO

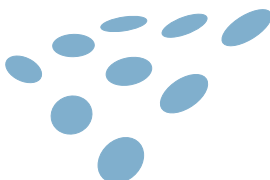

Desenhos 3 - Suporte de ventilador

MEDIDAS EM MILÍMETRO

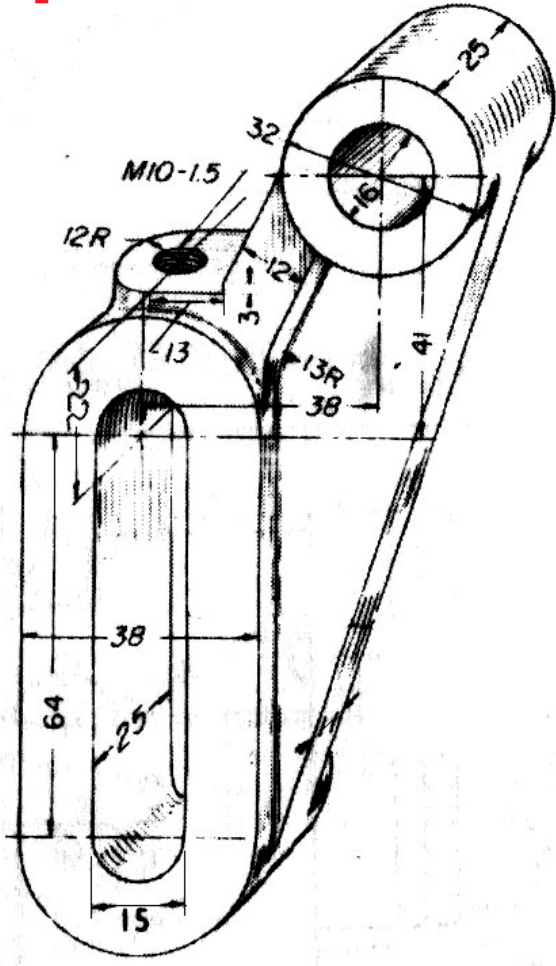

Desenhos 4 - Suporte

MEDIDAS EM MILÍMETRO

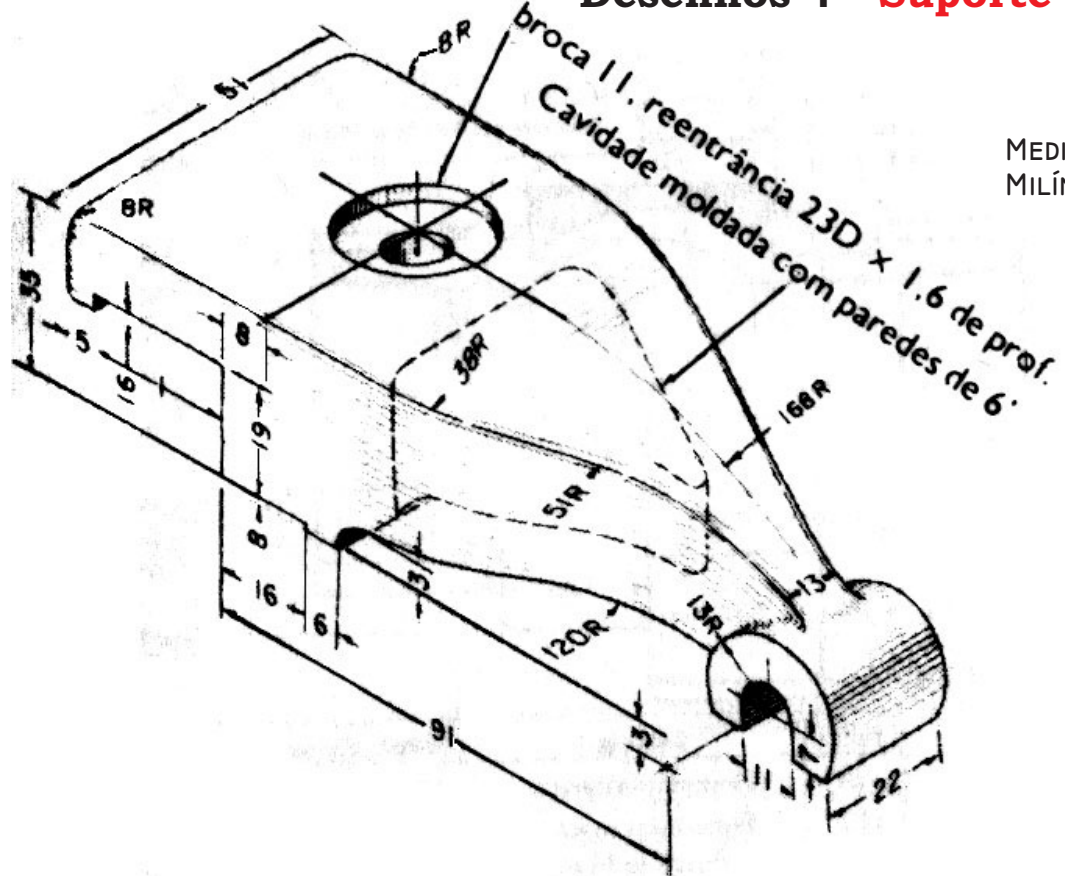

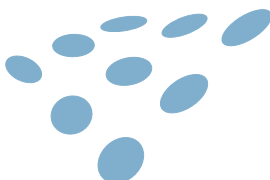

Desenhos 5 - Clipe de catenária

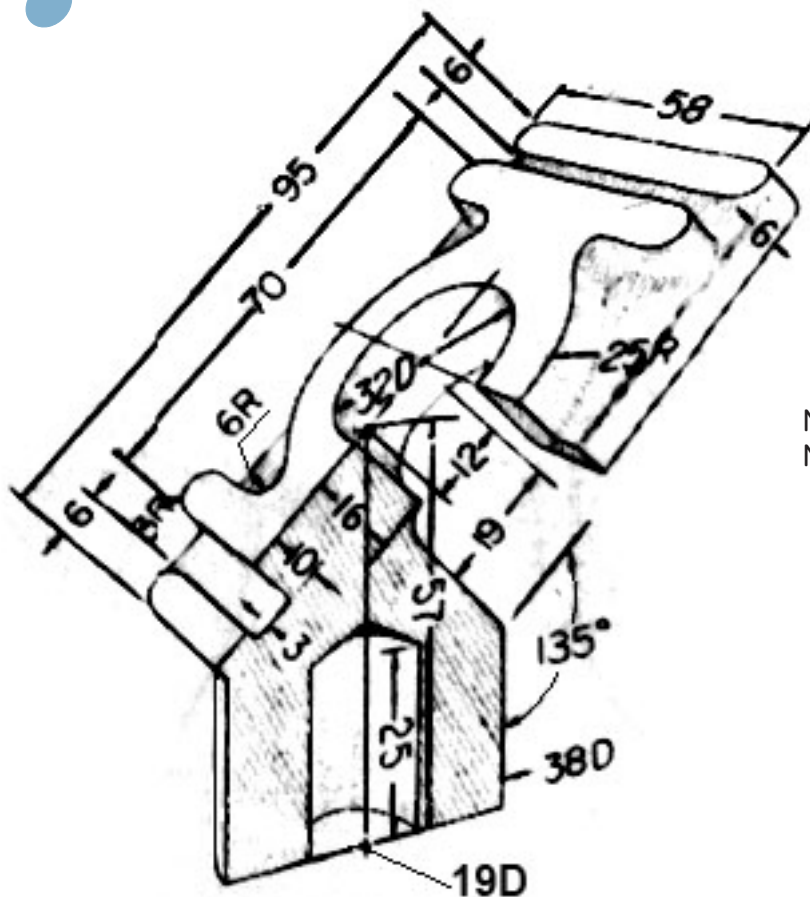

MEDIDAS EM
MILÍMETRO

Desenhos 6 Braço de engrenagem

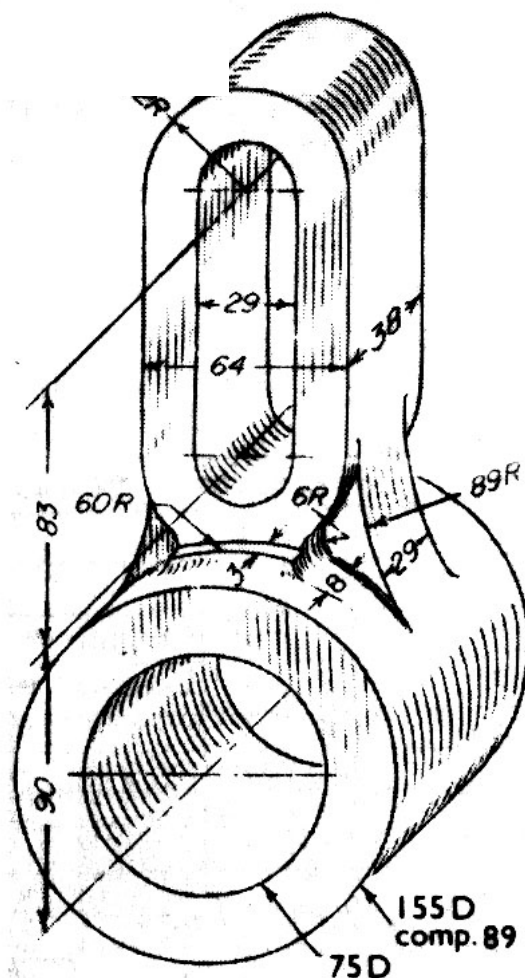

MEDIDAS EM
MILÍMETRO

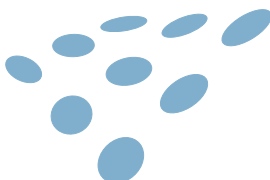

Desenhos 13 - **Mancal**

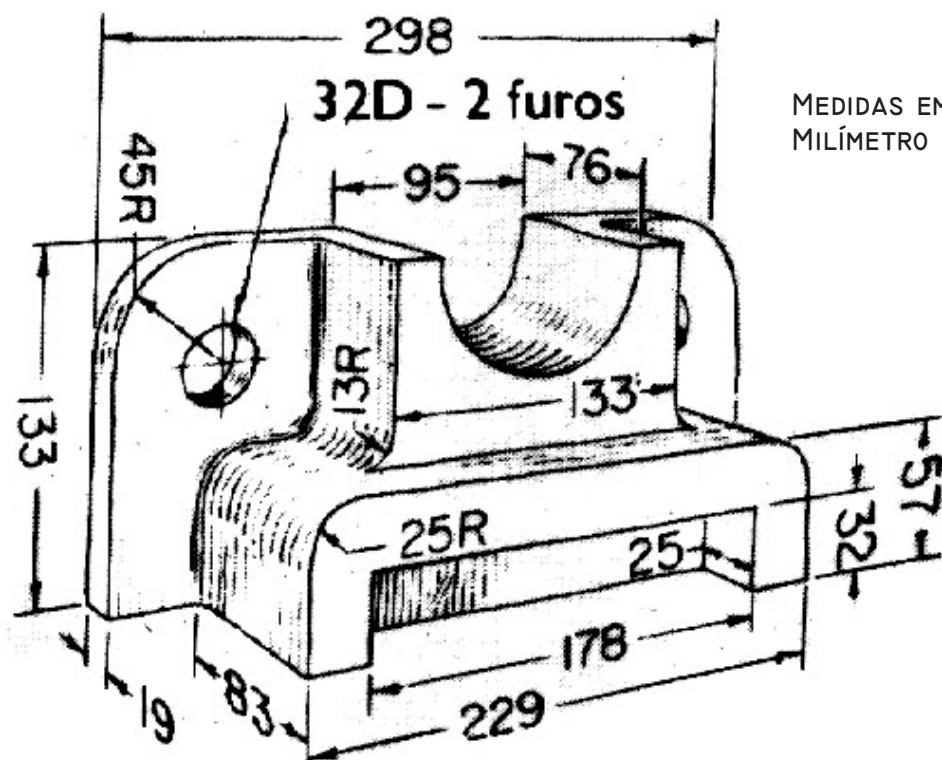

MEDIDAS EM MILÍMETRO

Desenhos 14 - **Caixilho de fixação**

MEDIDAS EM MILÍMETRO

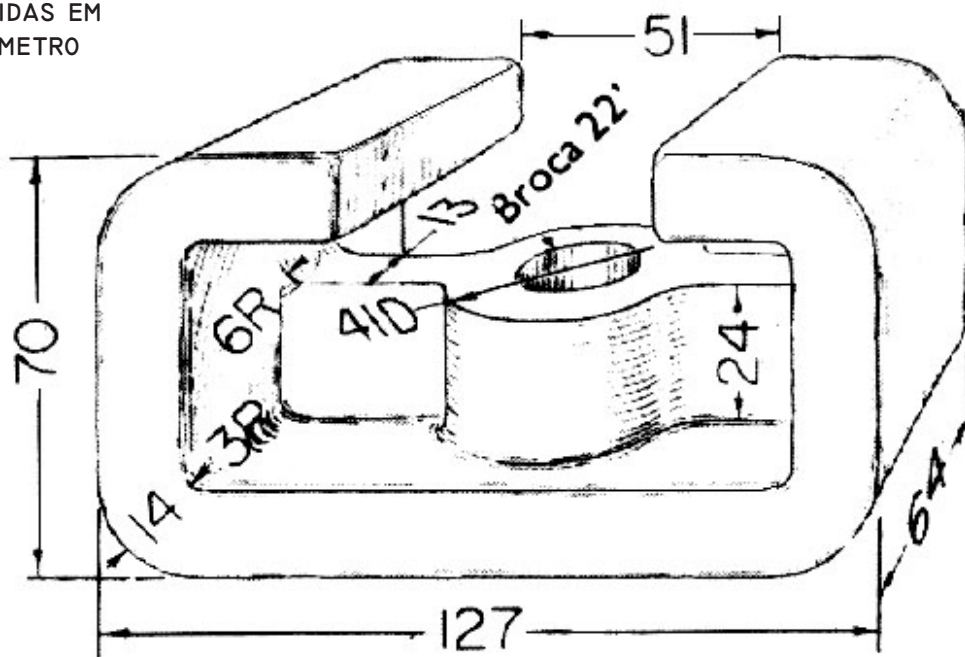

Desenhos 15 - **Corpo de extrator**

MEDIDAS EM
POLEGADA

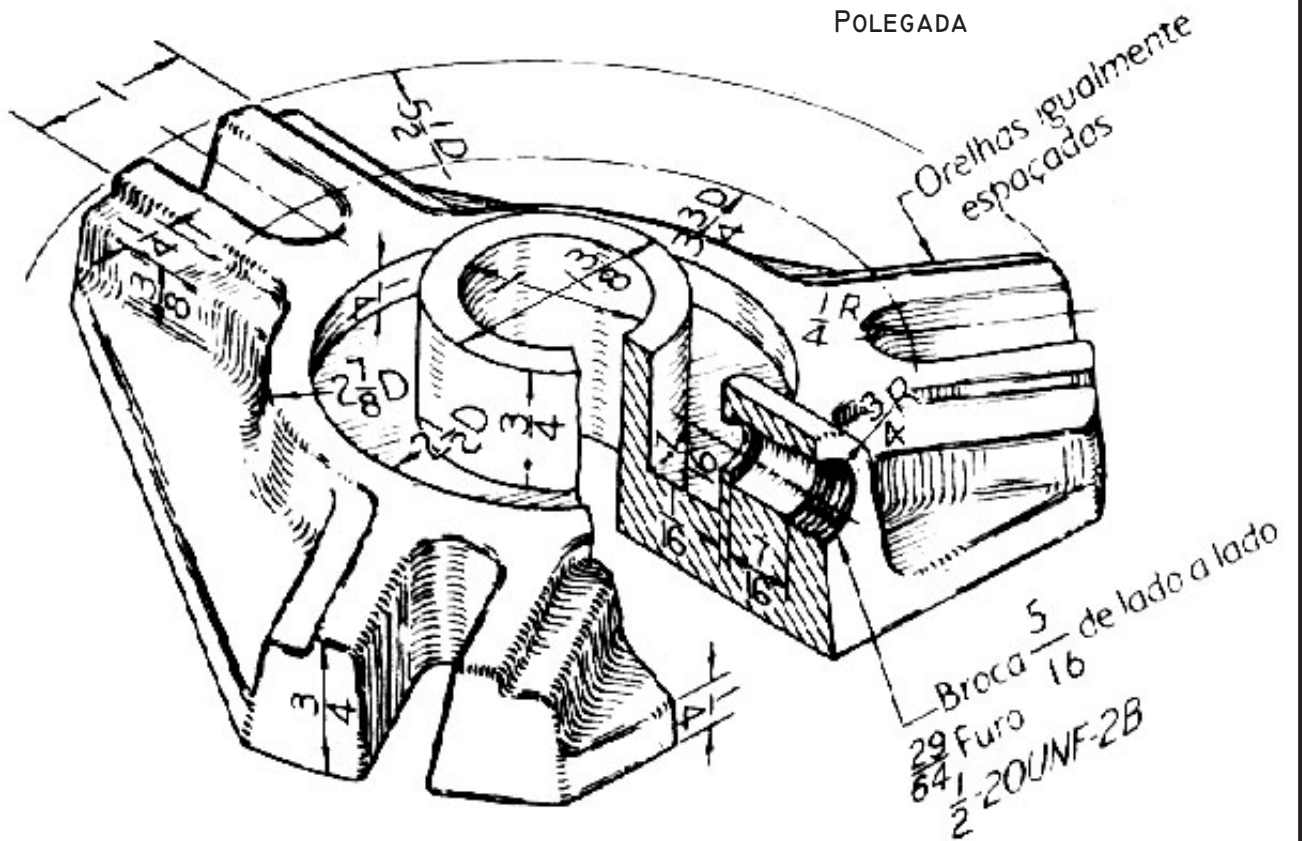

Desenhos 16 - **Virola para arame**

MEDIDAS EM
MILÍMETRO

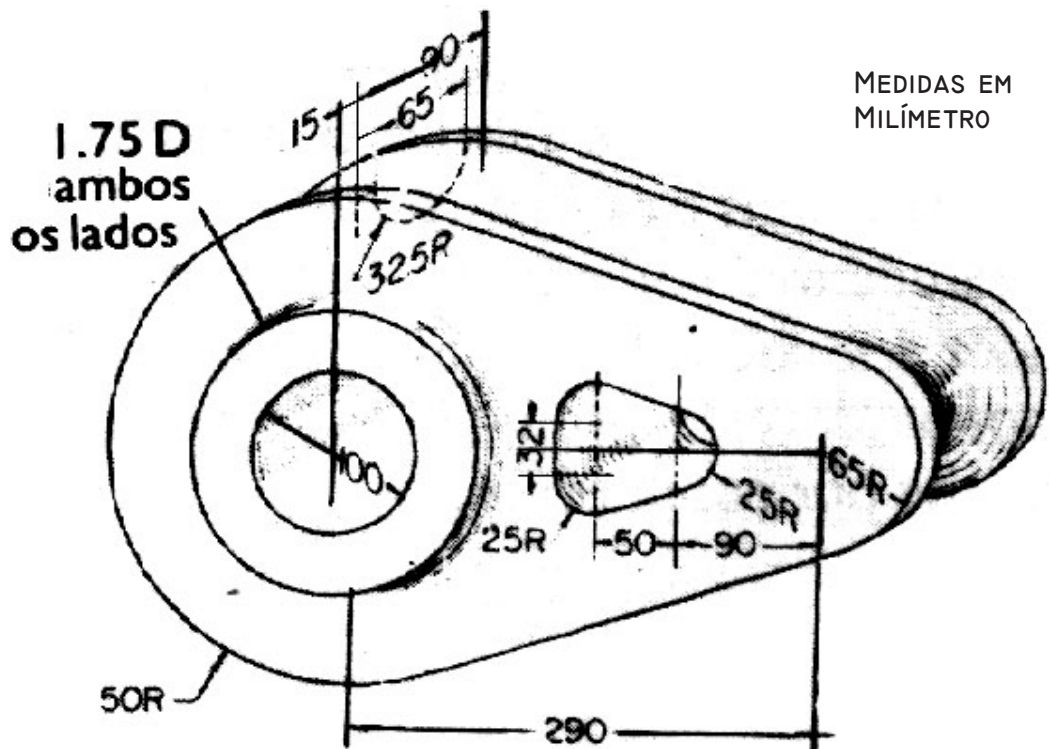

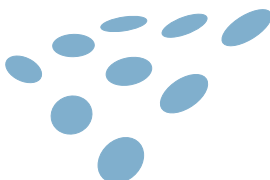

Desenhos 19 - Biela atuante

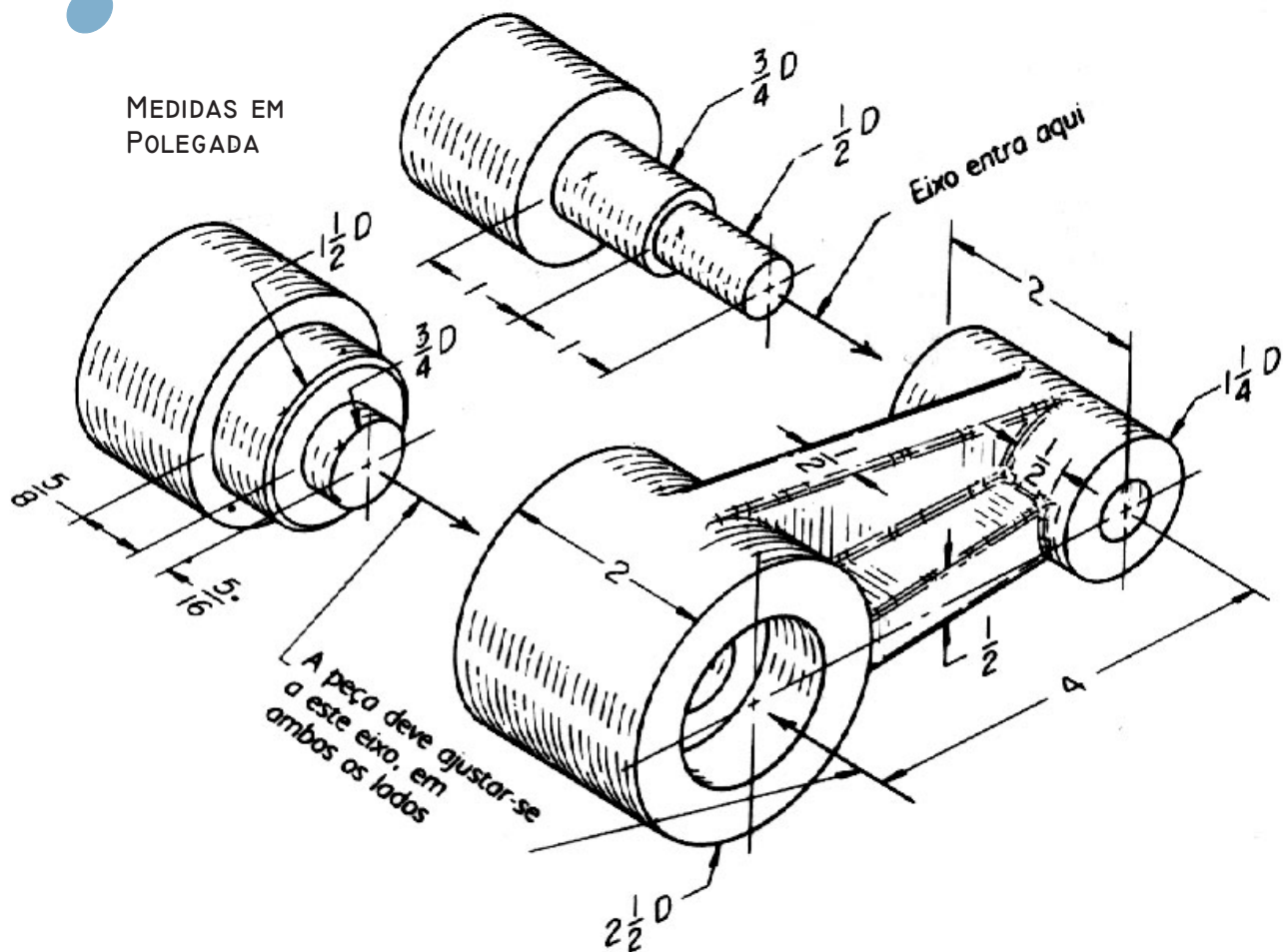

Desenhos 20 - Suporte de porta

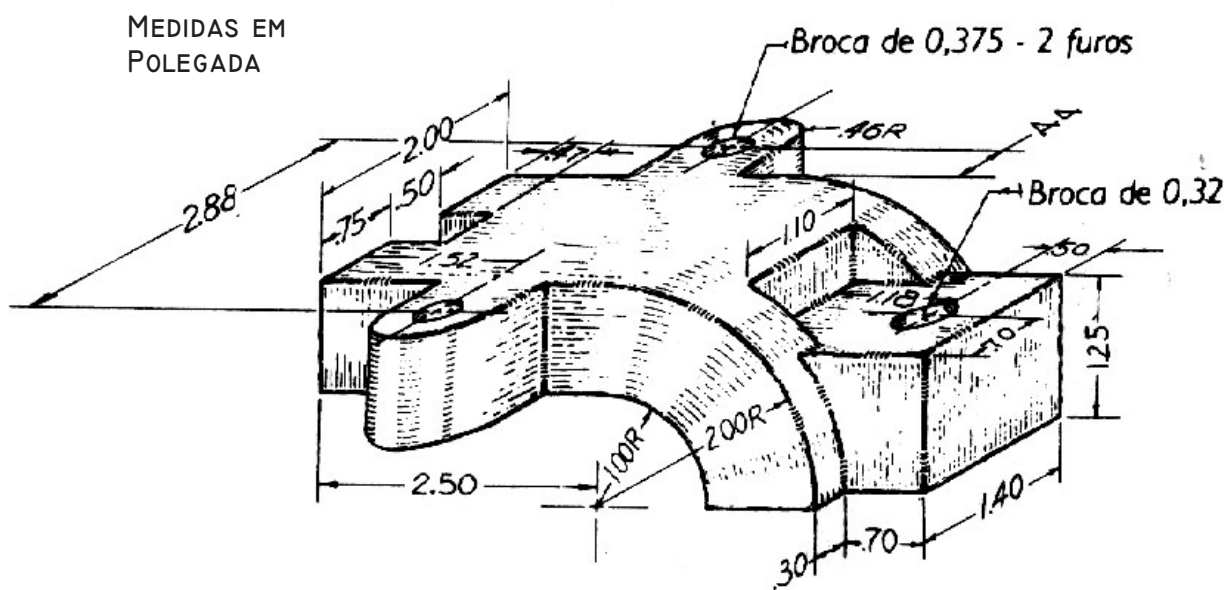

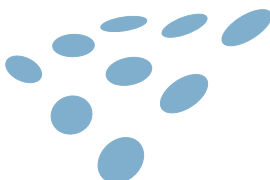

Desenhos 23 - Suporte giroscópico de projétil

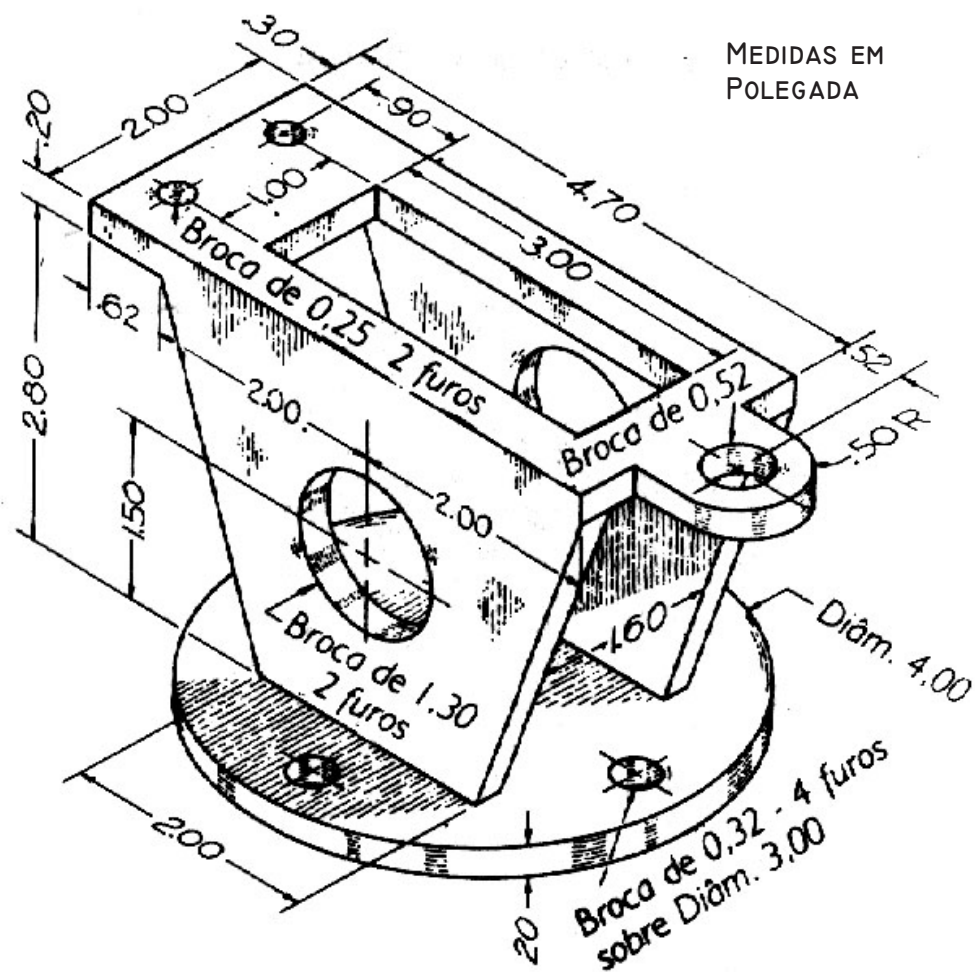

Desenhos 24 - Lingueta de ejeção de projétil

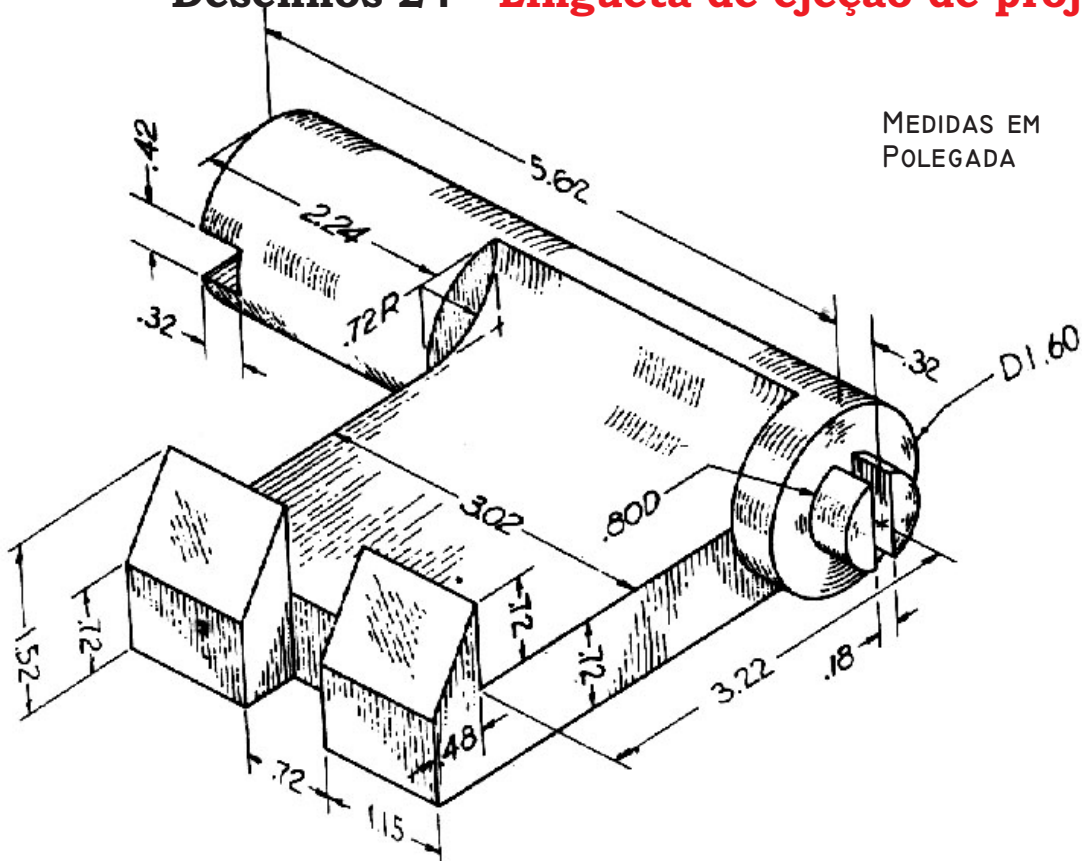

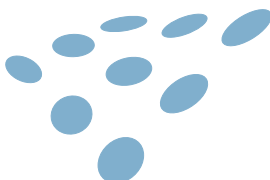

Desenhos 27 - Junta articulada

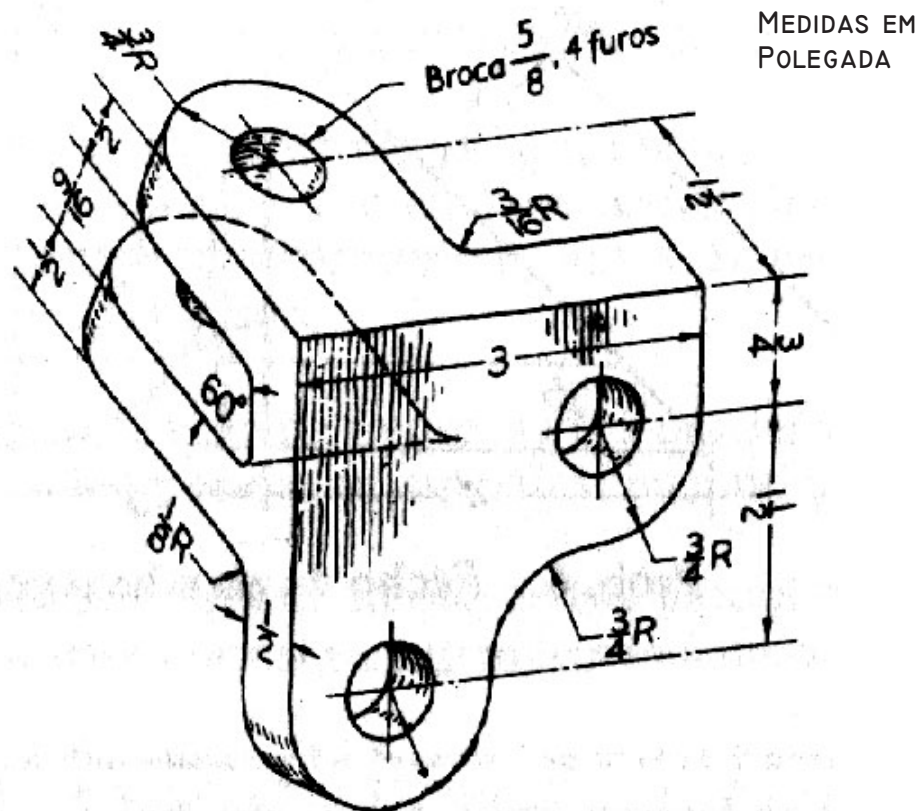

Desenhos 28 - Presilha angular

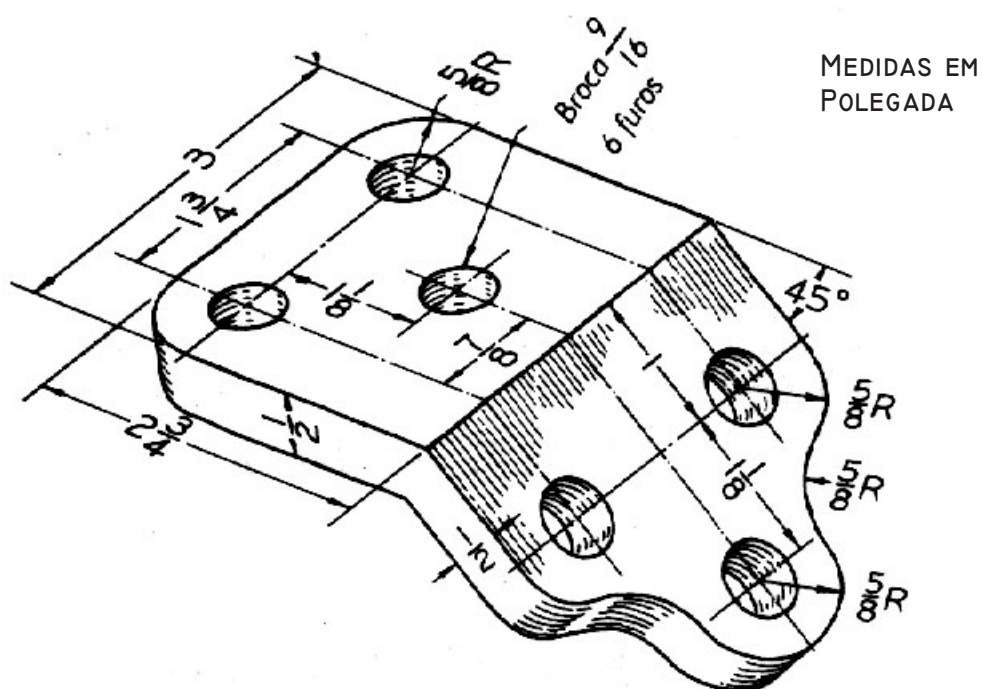

Desenhos 33 - Guia de eixo

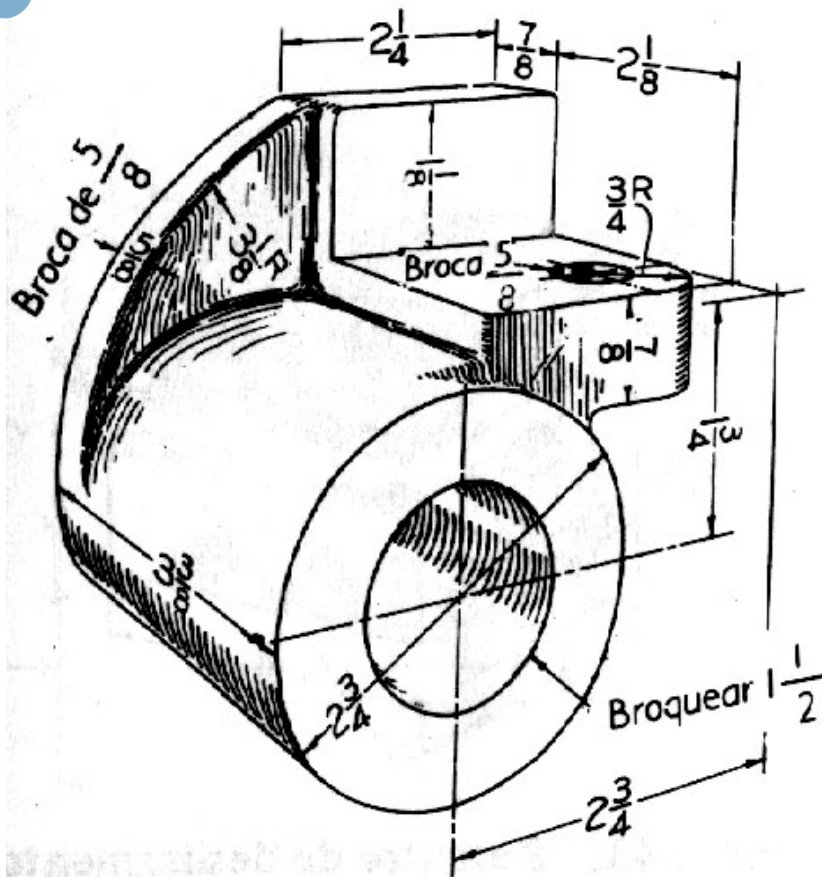

MEDIDAS EM
POLEGADA

Desenhos 34 - Bloco de fixação

MEDIDAS EM
POLEGADA

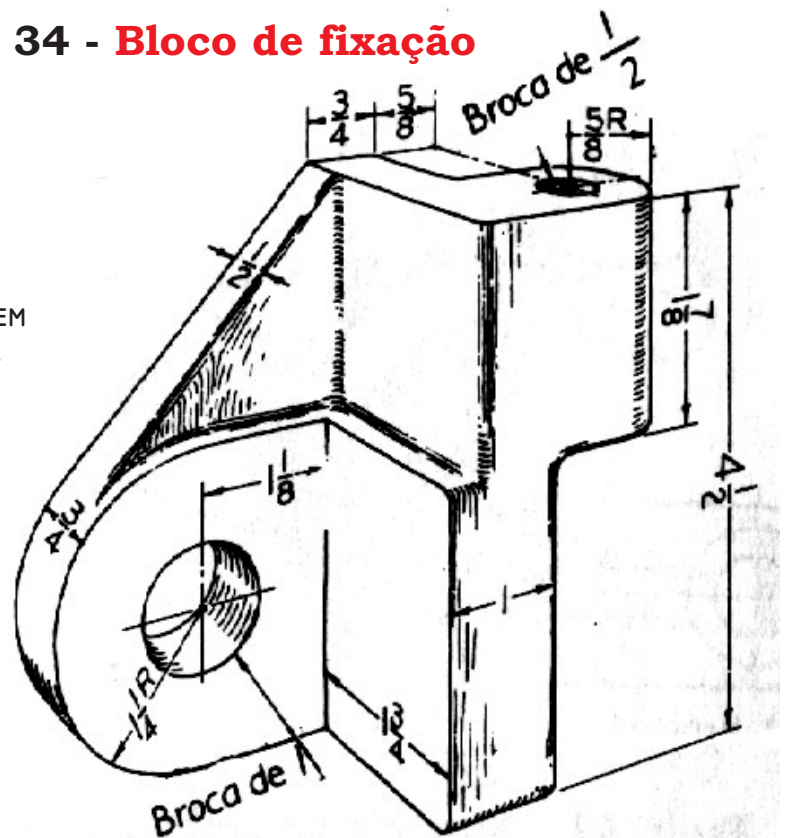

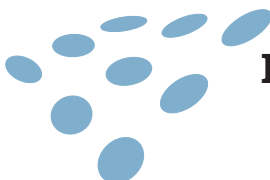

Desenhos 39 - Suporte de interruptor plástico

MEDIDAS EM
POLEGADA

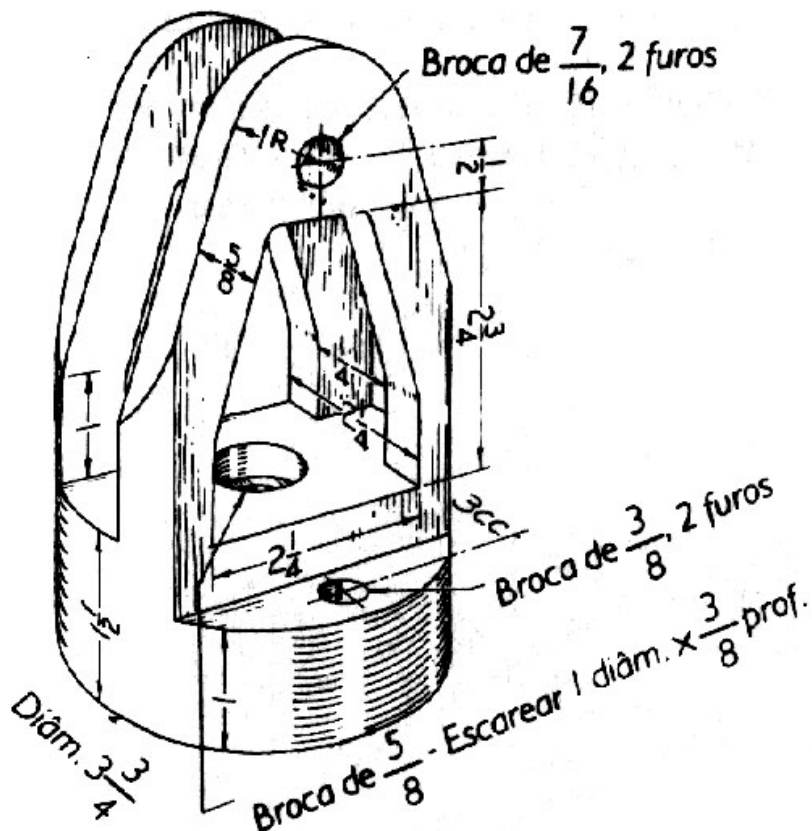

Desenhos 40 - Placa terminal

MEDIDAS EM
POLEGADA

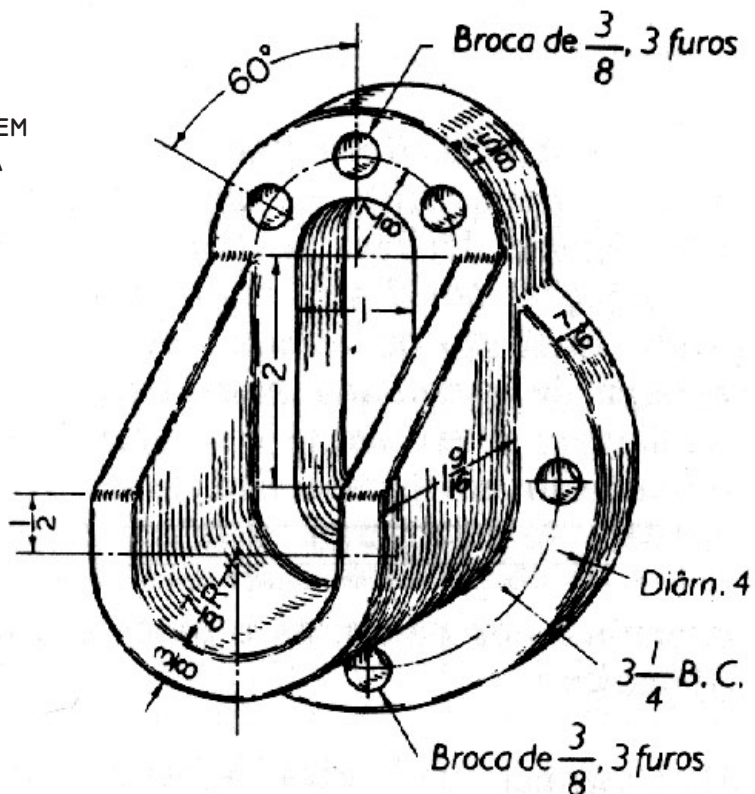

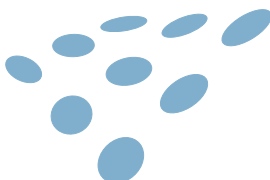

Desenhos 45 - Braço de fixação

MEDIDAS EM
POLEGADA

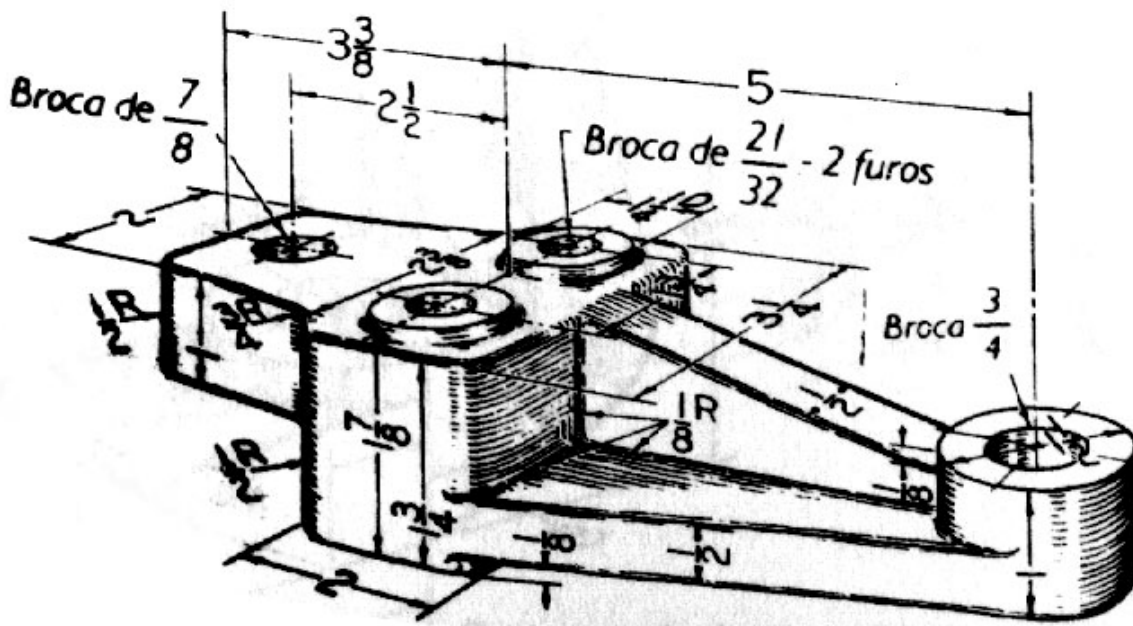

Desenhos 46 - Batente da placa de fixação

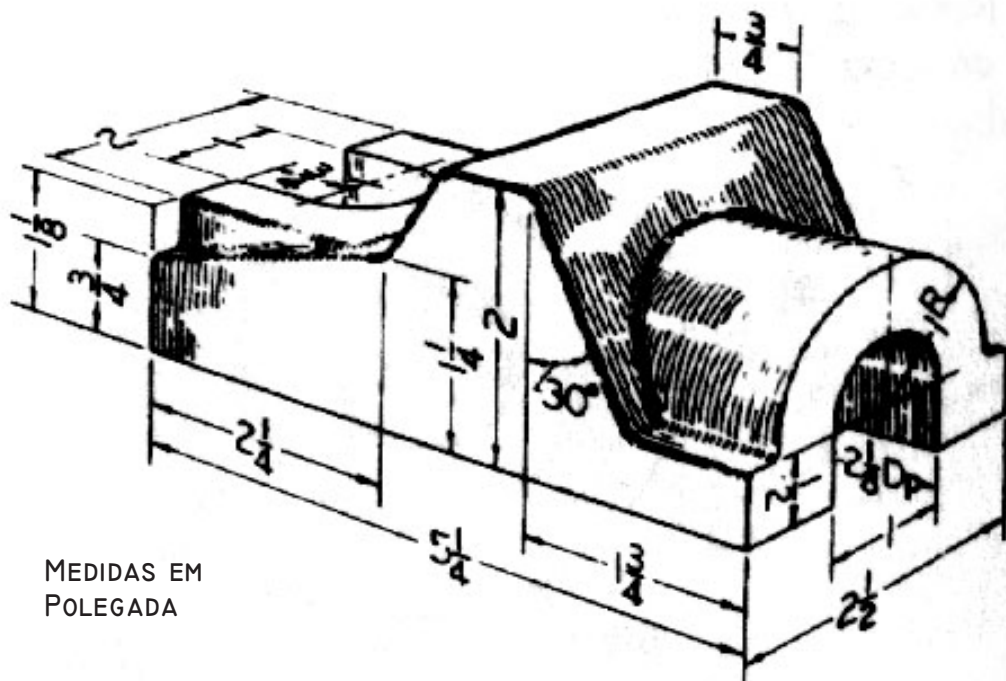

MEDIDAS EM
POLEGADA

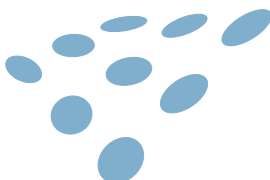

Desenhos 47 - Suporte de engate

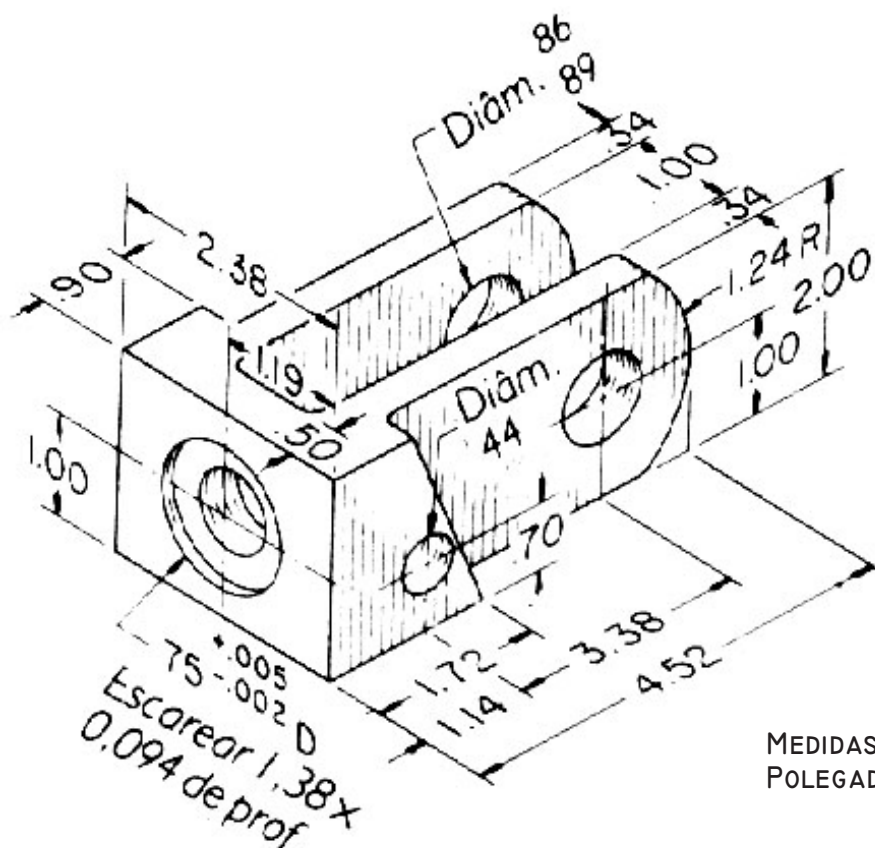

Desenhos 48 - Encaixe auxiliar

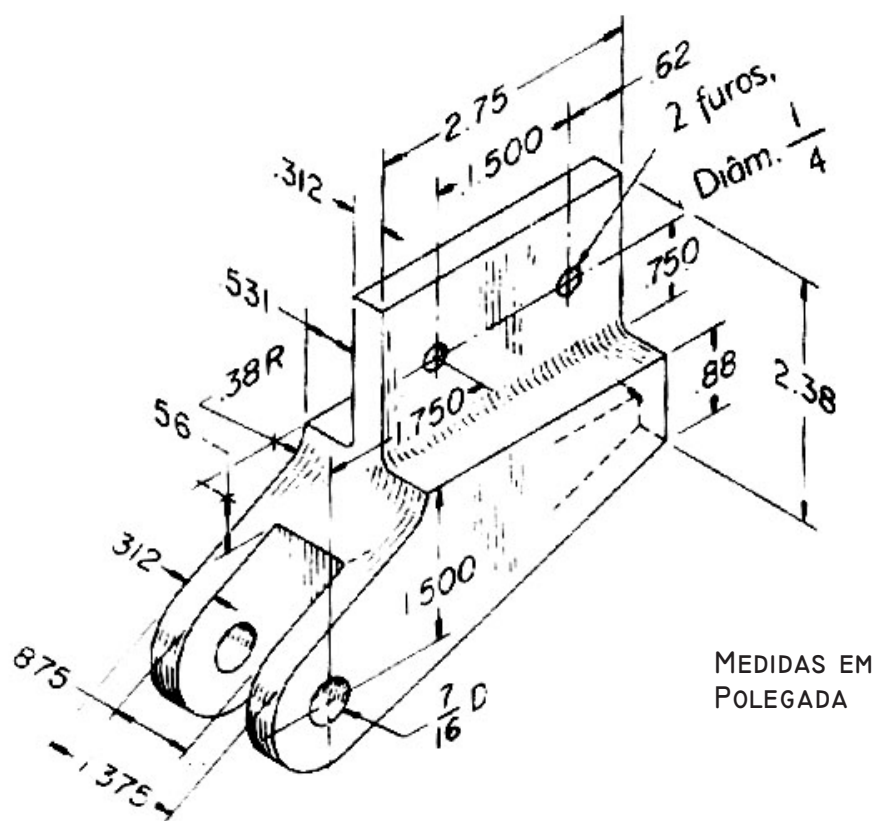

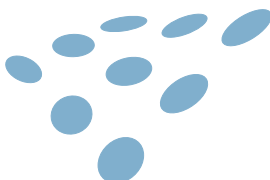

Desenhos 49 - Manivela de controle

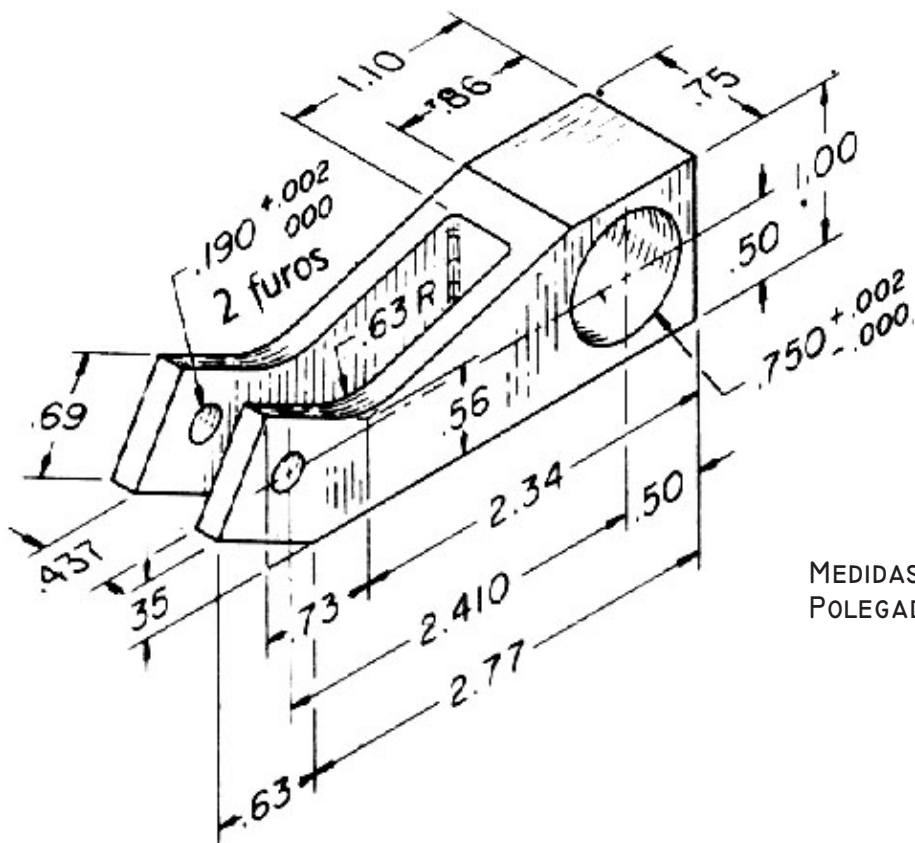

MEDIDAS EM POLEGADA

Desenhos 50 - Suporte de deslizamento

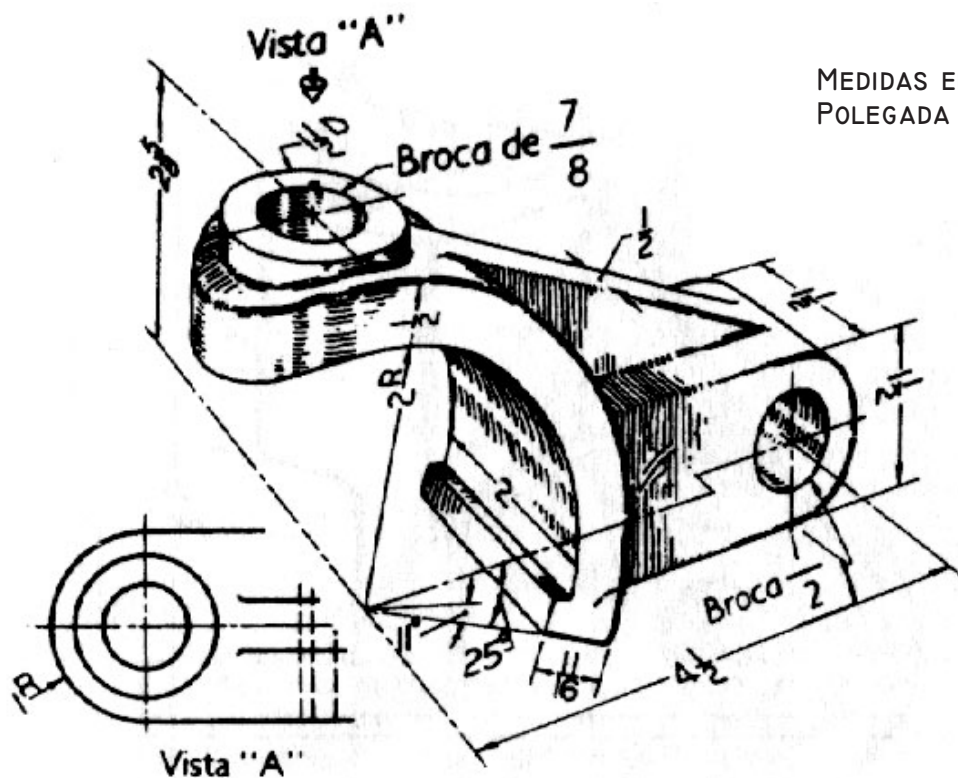

MEDIDAS EM POLEGADA



Desenhos 51 - Retentor de deslizamento

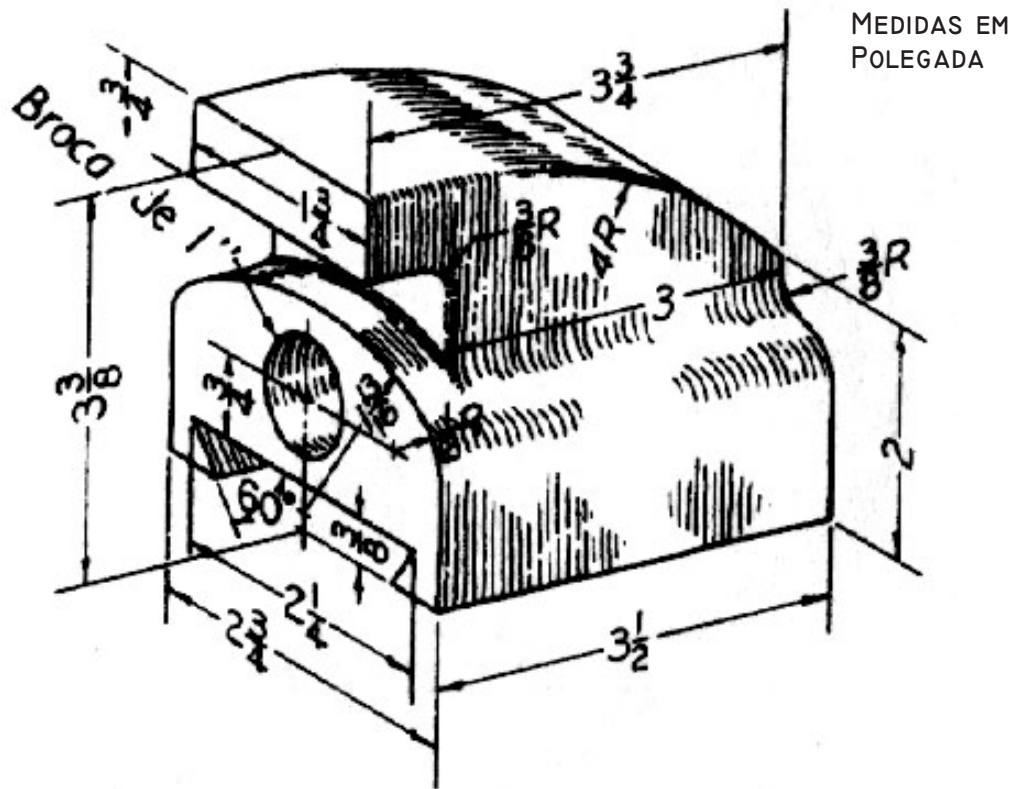

Desenhos 52 - Suporte de tubo

