

Capítulo 03

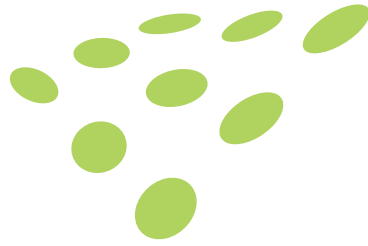

Perspectiva Isométrica

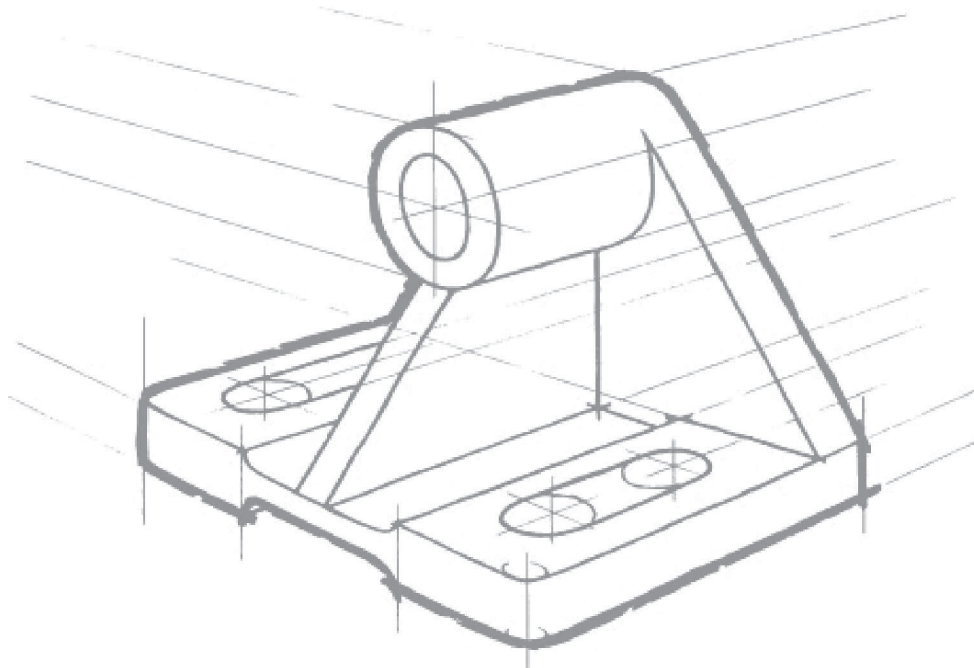

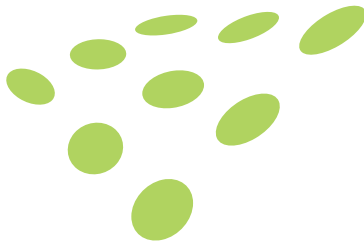

Desenho em Perspectiva

Quando olhamos para um objeto, temos a sensação de profundidade e relevo. Para transmitir essa idéia ao desenho, é necessário recorrer a um modo especial de representação gráfica: a perspectiva. Ela representa graficamente as três dimensões de um objeto em um único plano, de maneira a transmitir a idéia de profundidade e relevo.

Existem diferentes tipos de perspectiva. Veja como fica a representação de um cubo em três tipos diferentes de perspectiva:

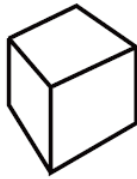

perspectiva cônica



perspectiva cavaleira

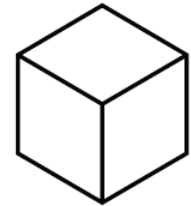

perspectiva isométrica

Perspectiva Cônica

A perspectiva cônica é a forma de representação em perspectiva que mais se assemelha com a percepção que nossos olhos tem de perspectiva. Ela altera as dimensões e a inclinação das arestas de modo a representar a conicidade em direção a um ou mais pontos de fuga.

Em desenho mecânico esse tipo de representação em perspectiva não é usual pois representa o componente de forma bastante deformada, ou seja, não em verdadeira grandeza.

Exemplos de representações em perspectiva cônica

1 ponto de fuga:

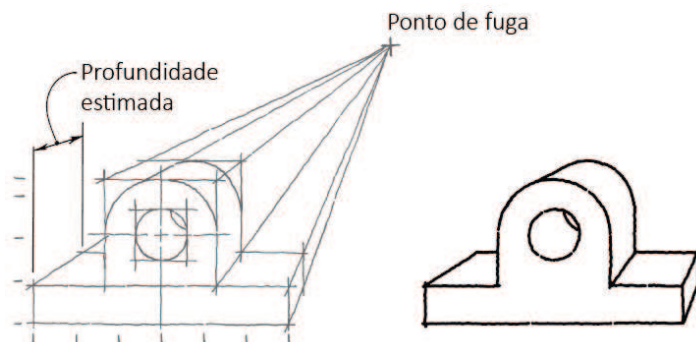

2 pontos de fuga:

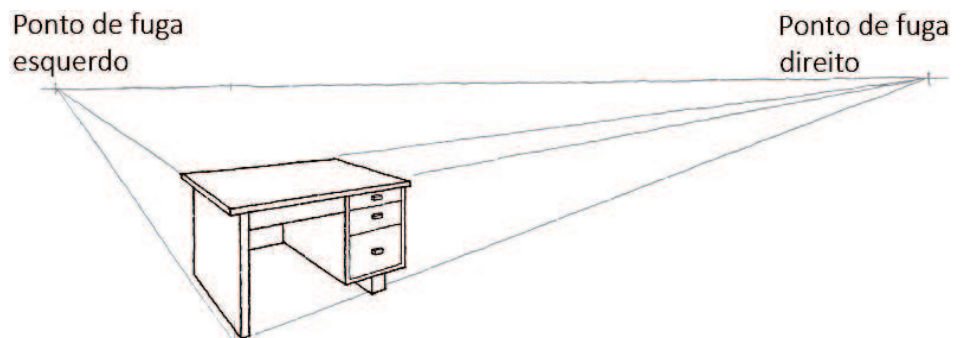

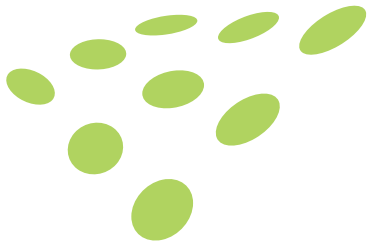

Desenho em Perspectiva

Perspectiva Cavaleira

Na representação em perspectiva cavaleira a face frontal da peça é representada em verdadeira grandeza. Ou seja, todas as arestas tem a dimensão e a inclinação real, mas as arestas que representam a profundidade sofrem alteração. Existem três tipos de representar essa profundidade, são eles, inclinar as arestas perpendiculares da profundidade 30°, 45° ou 60°, conforme pode ser visto abaixo.

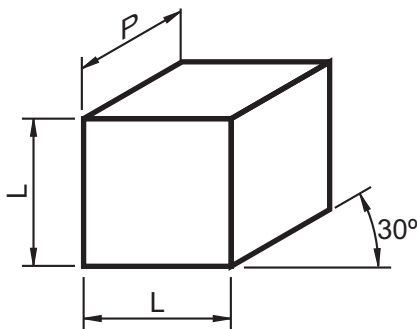

$$P = 2 / 3 L$$

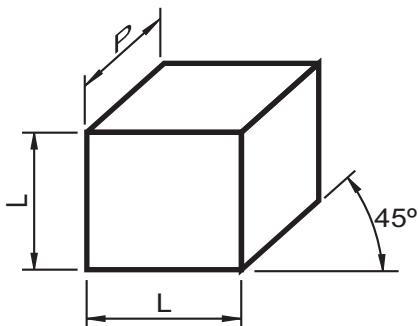
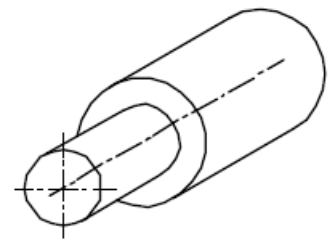

$$P = 1 / 2 L$$

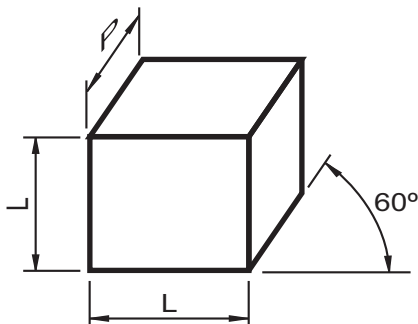
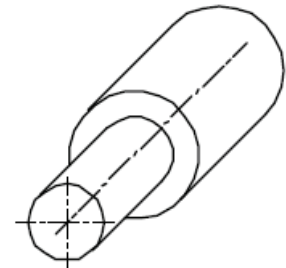

$$P = 1 / 3 L$$

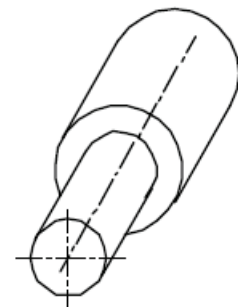

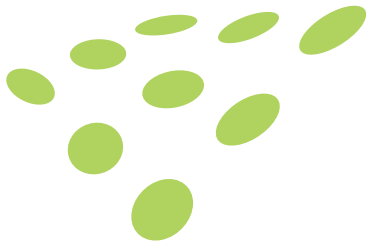

Desenho em Perspectiva

Perspectiva Isométrica

Cada tipo de perspectiva (Cônica, Cavaleira e Isométrica) mostra o objeto de um jeito. A perspectiva isométrica é a que representa o objeto de forma menos deformada pois mantém as mesmas proporções do comprimento, da largura e da altura do objeto representado.

Devido a isso, a representação em perspectiva isométrica é a forma mais utilizada em desenho técnico mecânico.

Desenhos em perspectiva isométrica são feitos, geralmente, em folhas de papel reticulado com o objetivo de representar um esboços de peça existente ou para rascunhar uma peça nova.

Exemplos de representações em perspectiva isométrica

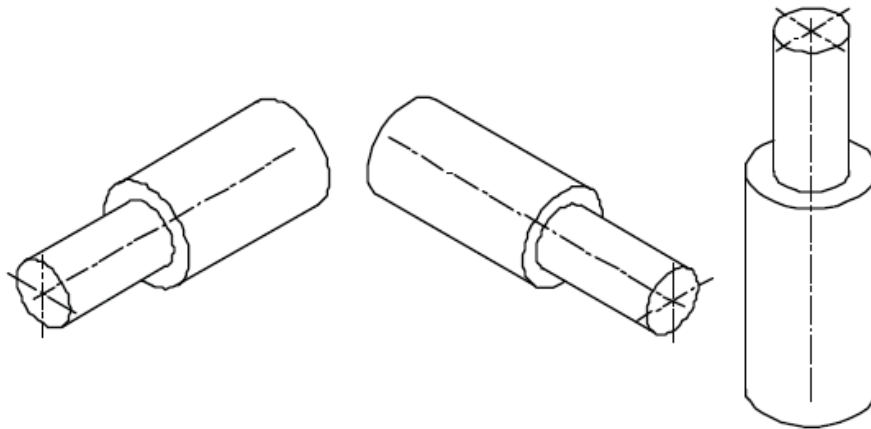

Ângulos de desenho

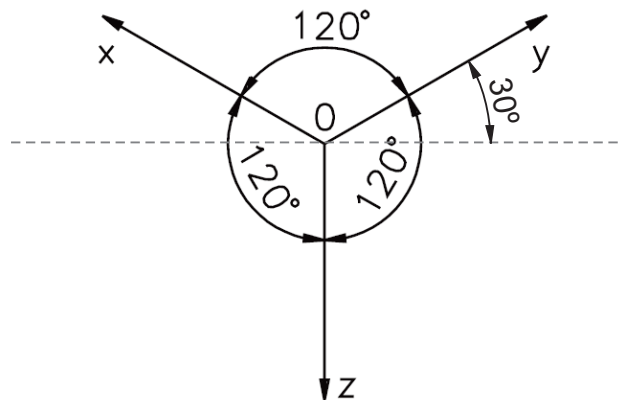

Desenhando perspectivas isométricas com esquadros

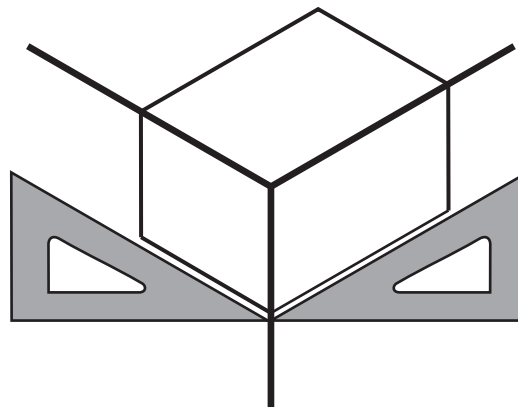

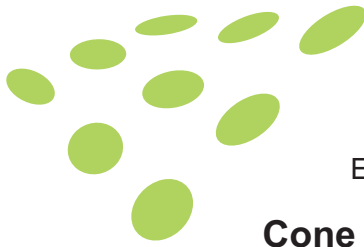

Perspectiva isométrica

Exemplos de desenhos isométricos utilizando papel reticulado

Cone

1ª fase - Trace a perspectiva isométrica do círculo na face superior e marque um ponto A no cruzamento das linhas que dividem o quadrado auxiliar.

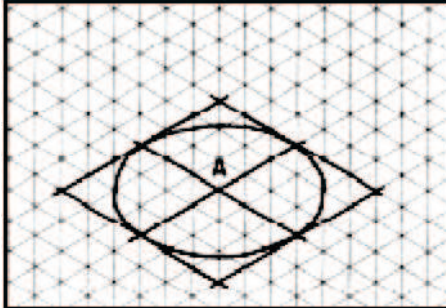

2ª fase - A partir do ponto A, trace a perpendicular AB.

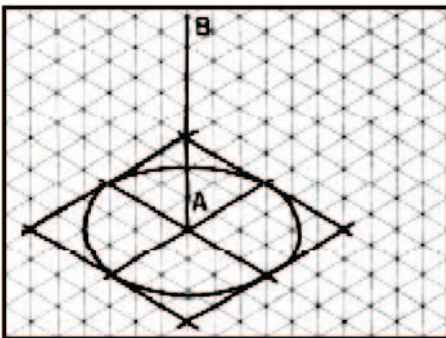

3ª fase - Ligue o ponto B ao círculo por meio de duas linhas conforme imagem abaixo.

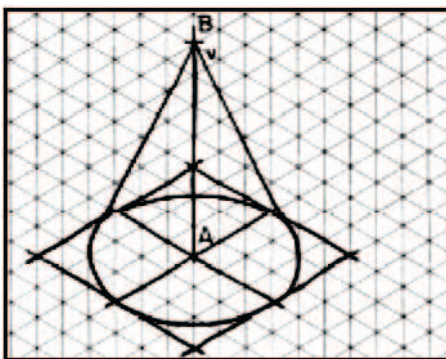

4ª fase - Apague as linhas de construção e reforçe o contorno do cone.

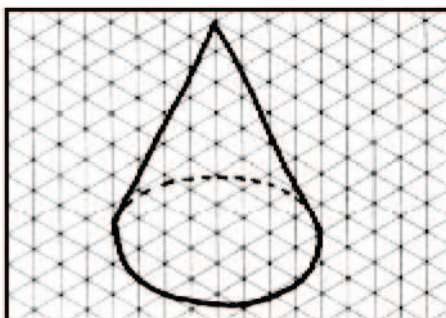

Peça prismática

1ª fase - Trace o prisma auxiliar respeitando o comprimento, a largura e a altura aproximados do prisma com elementos arredondados.

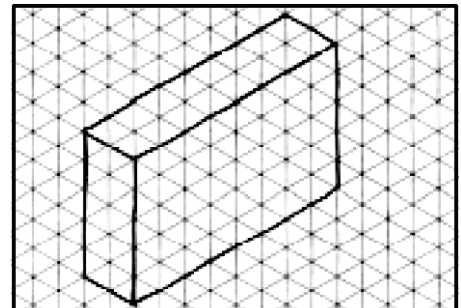

2ª fase - Marque, na face anterior e na face posterior, os semiquadrados que auxiliam o traçado dos semicírculos.

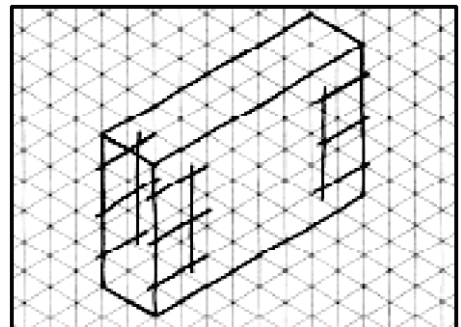

3ª fase - Trace os semicírculos que determinam os elementos arredondados, na face anterior e na face posterior do modelo.

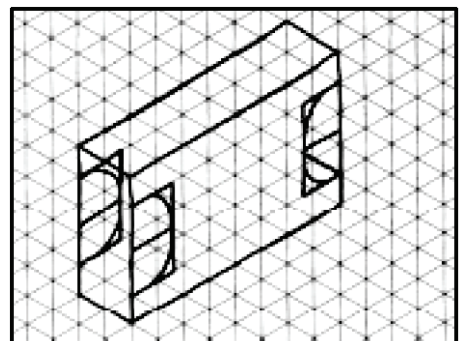

4ª fase - Apague as linhas de construção e reforçe o contorno do traçado.

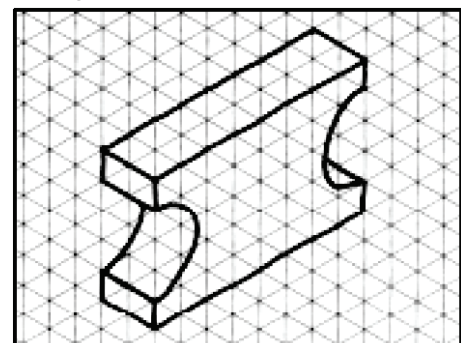

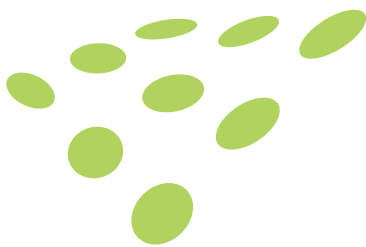

Desenho em Perspectiva

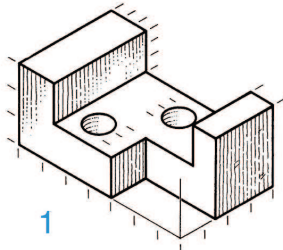

1

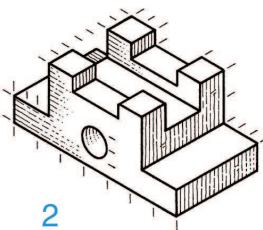

2

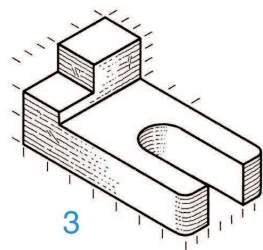

3

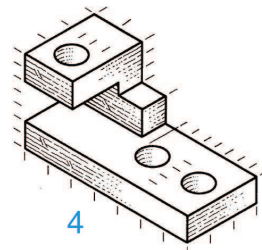

4

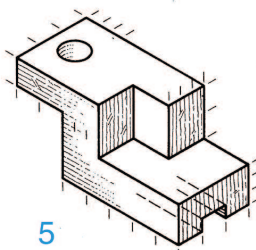

5

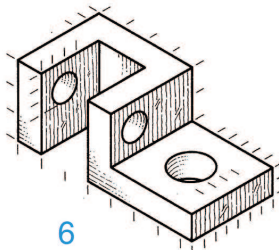

6

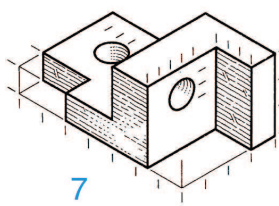

7

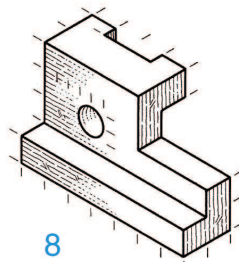

8

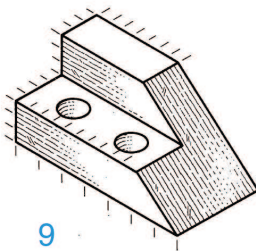

9

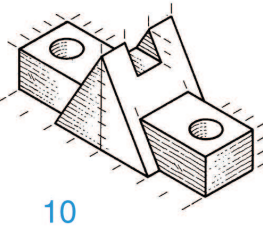

10

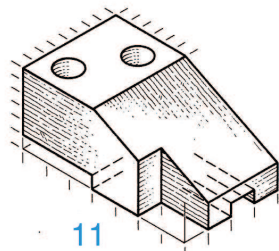

11

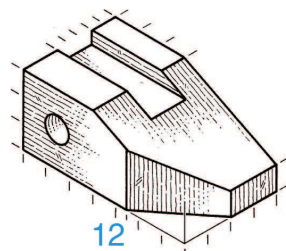

12

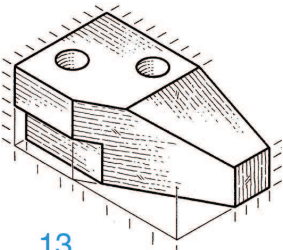

13

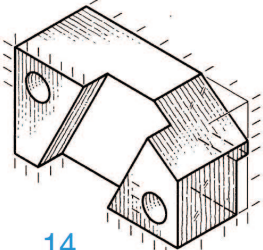

14

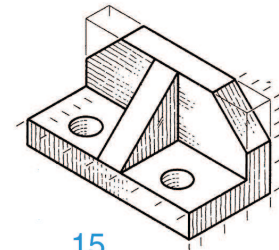

15

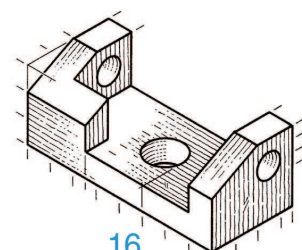

16

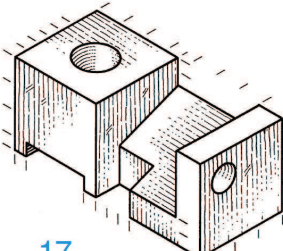

17

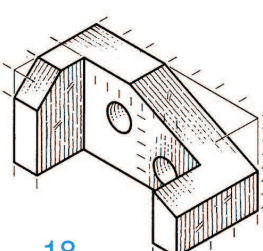

18

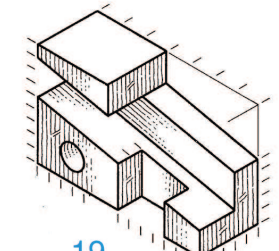

19

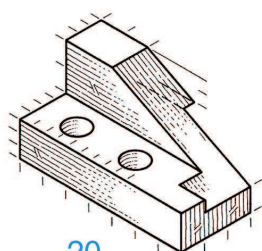

20

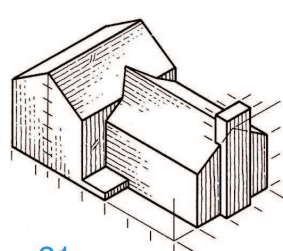

21

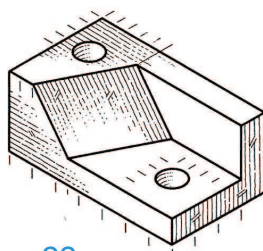

22

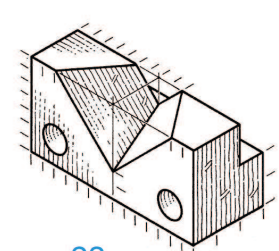

23

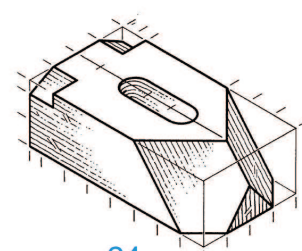

24

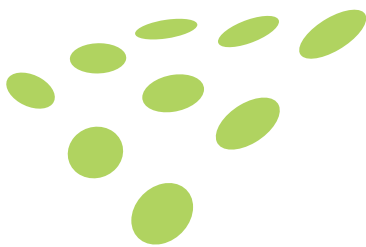

Desenho em Perspectiva

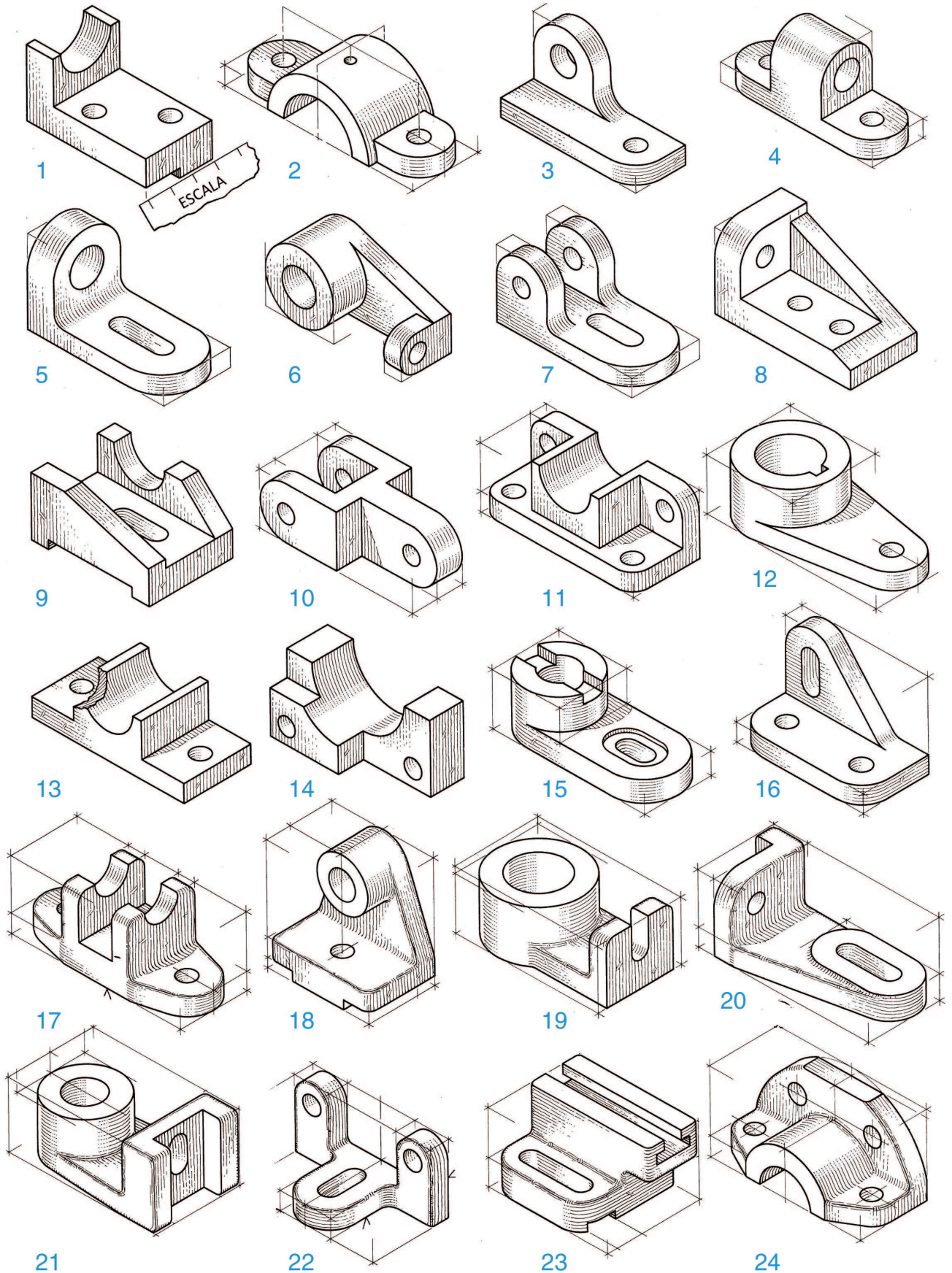

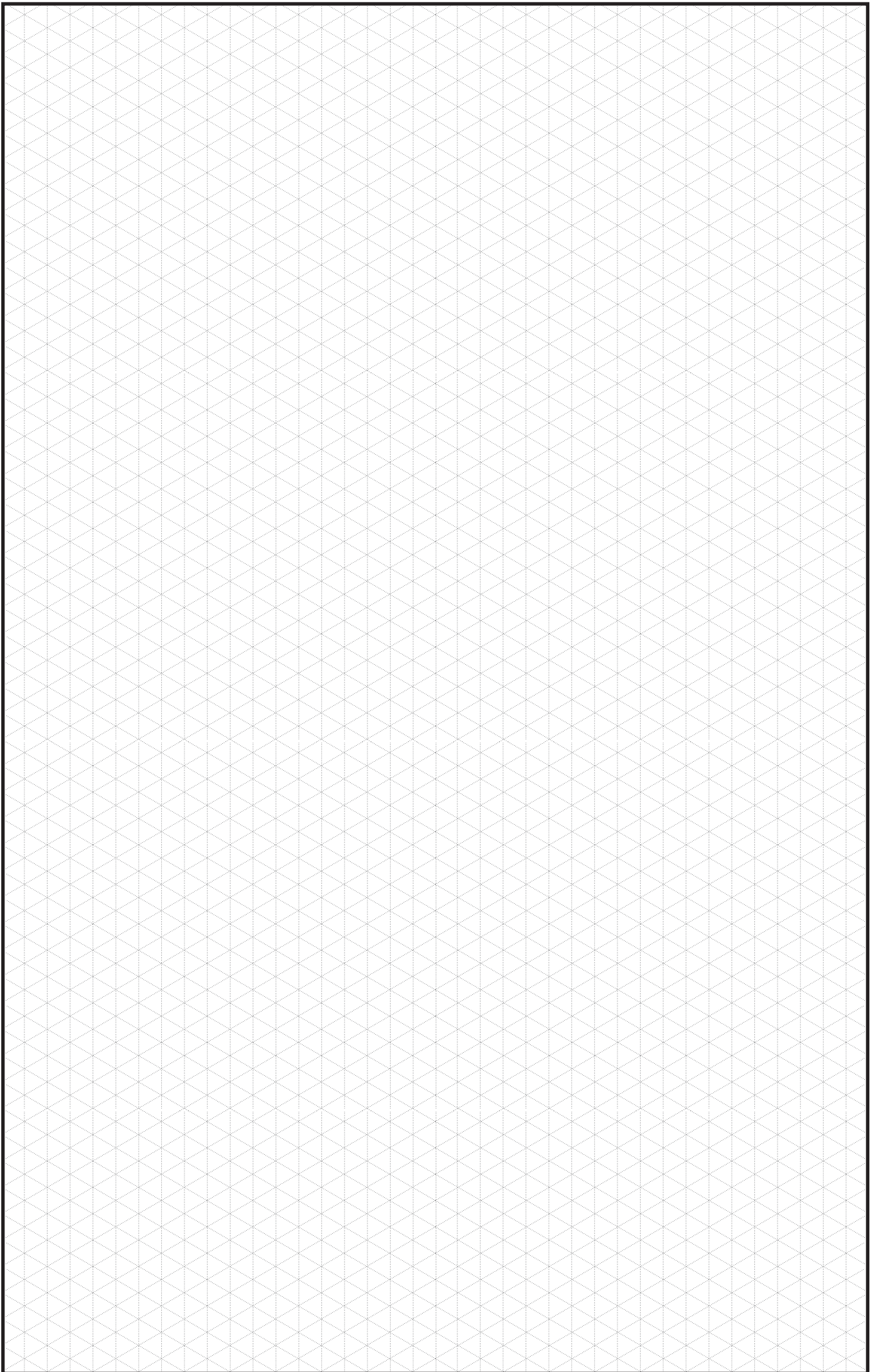

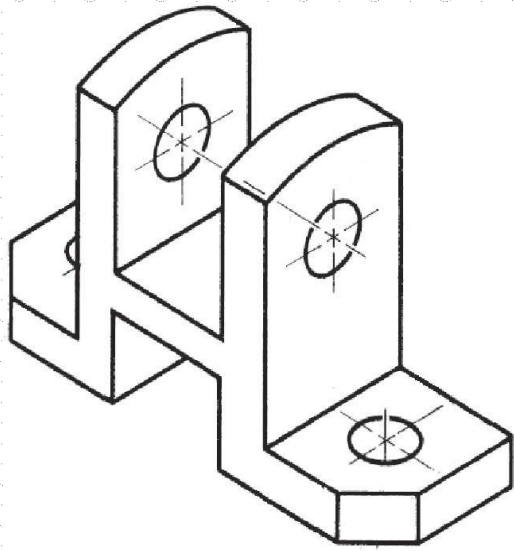

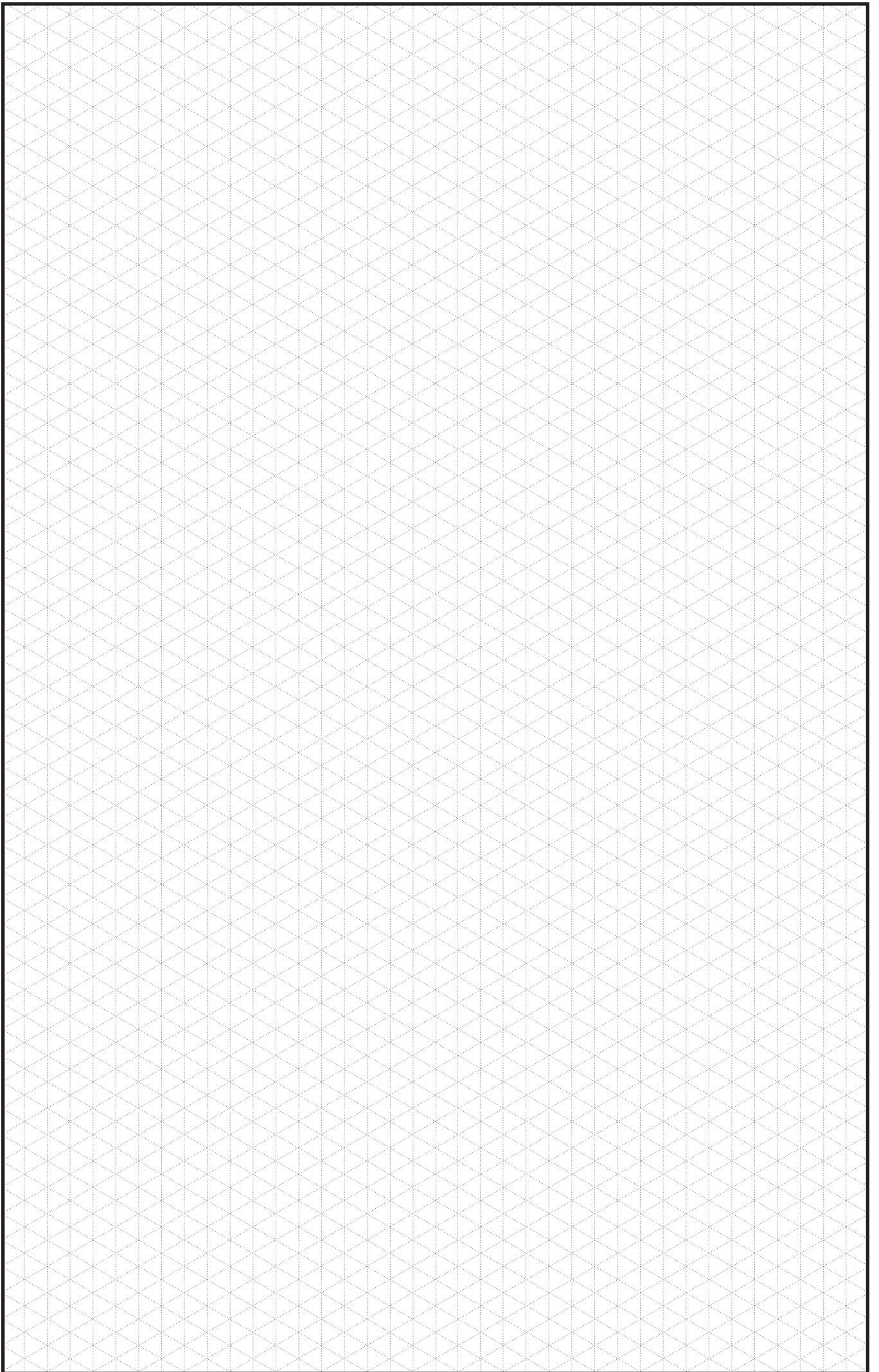

1

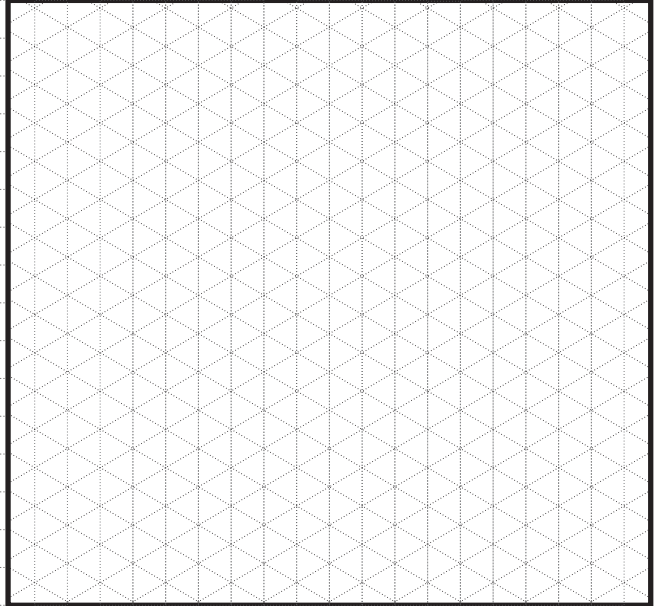
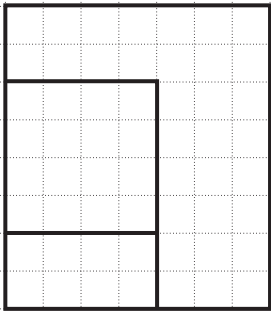
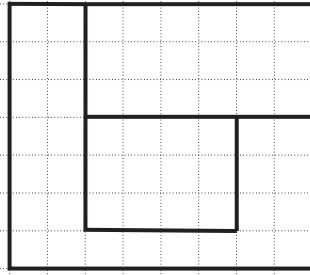
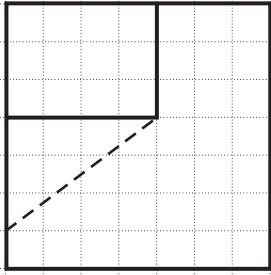

2

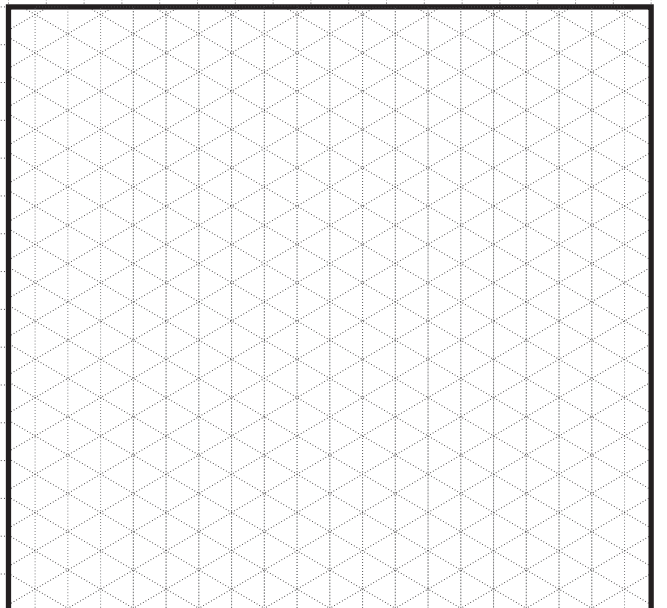
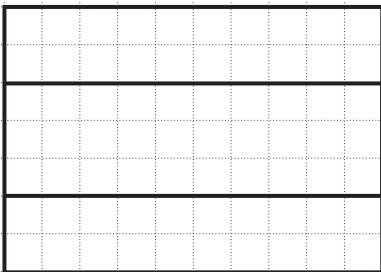
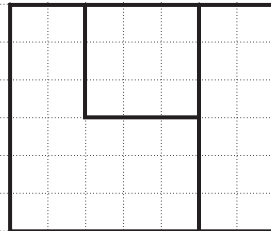
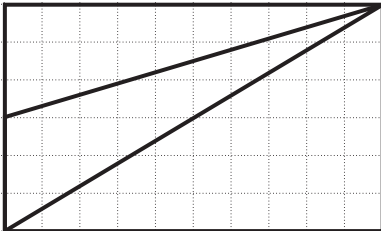

3

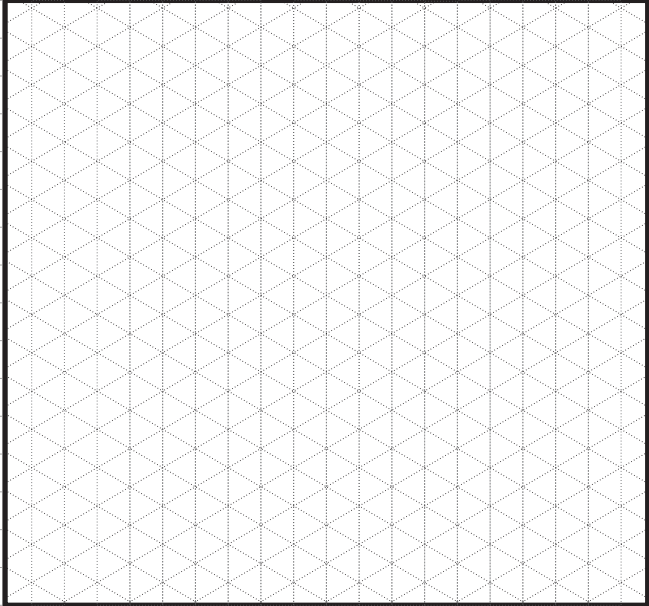
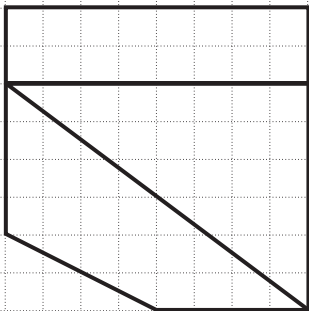
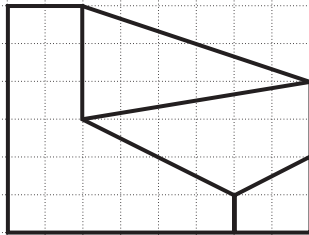
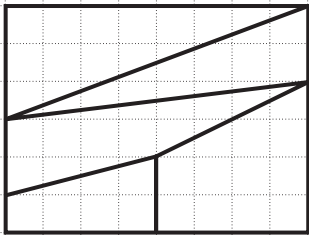

4

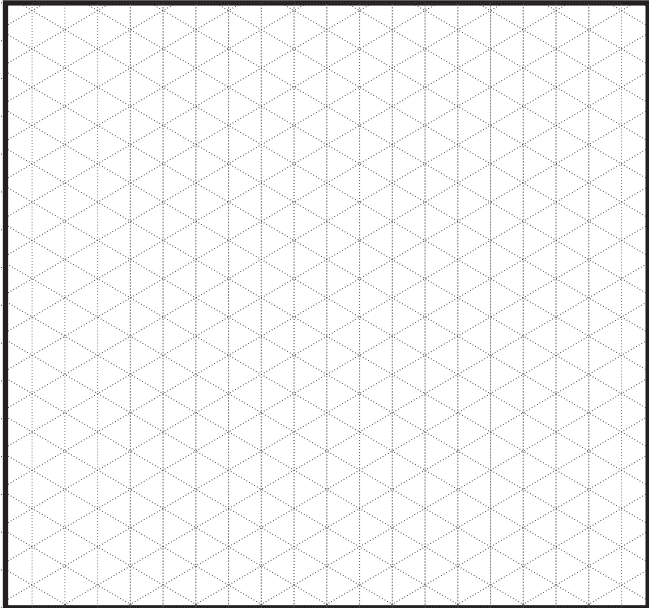
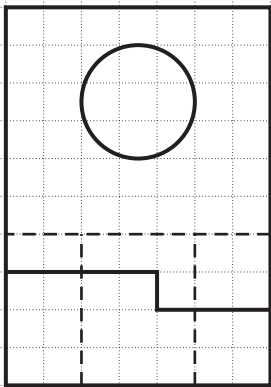
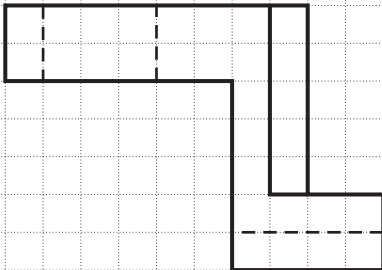
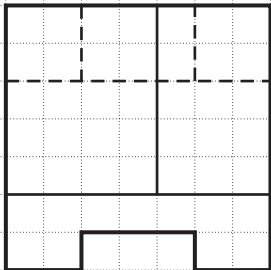

5

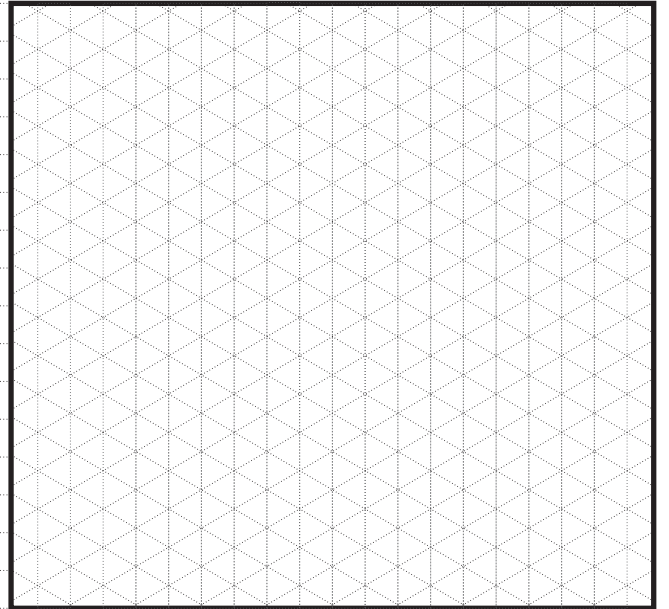
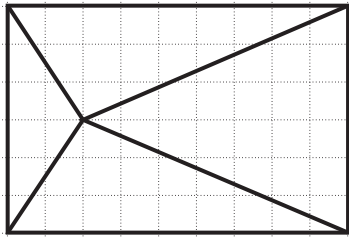
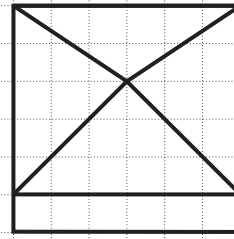
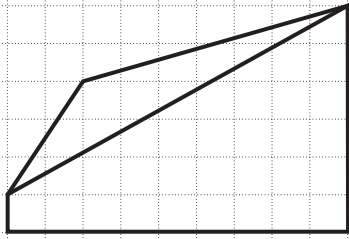

6

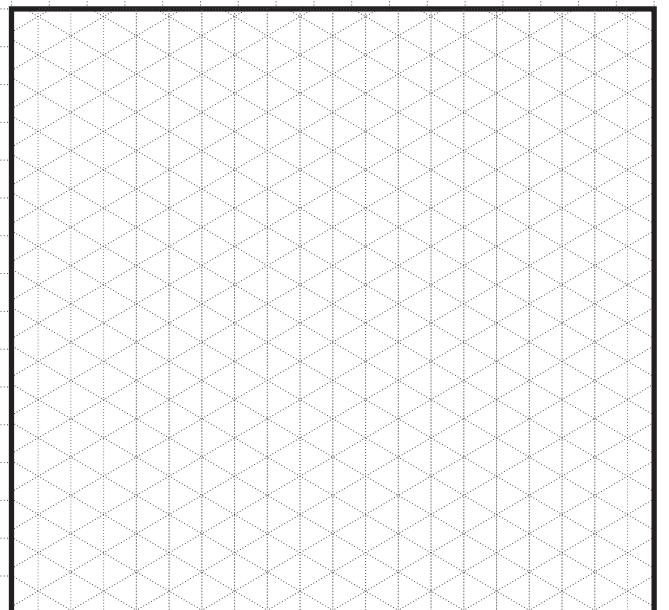
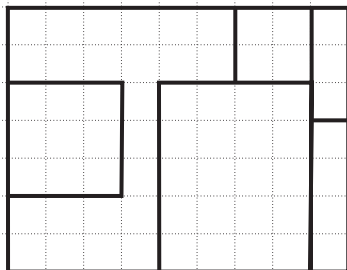
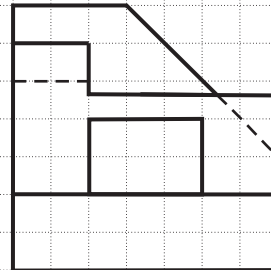
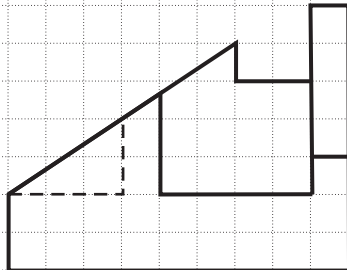

7

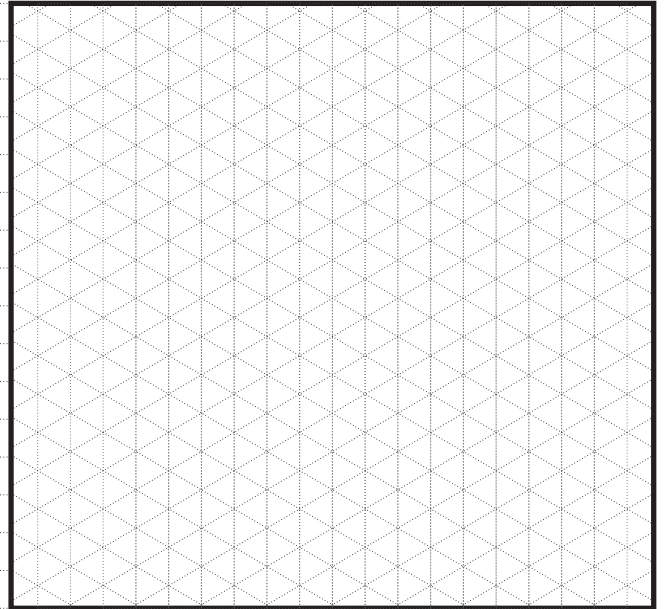
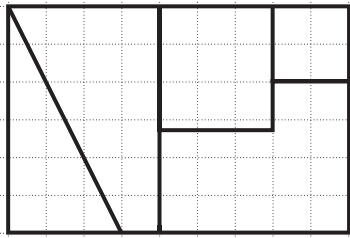
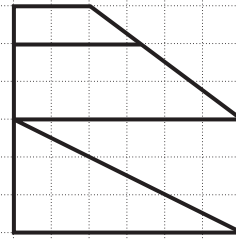
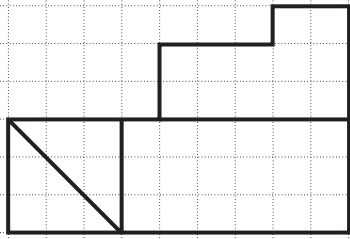

8

